

AMI Silica

Operator's Manual



SWISS  MADE



Customer Support

Swan and its representatives maintain a fully trained staff of technical specialists around the world. For any technical question, contact your nearest Swan representative, or the manufacturer:

Swan Analytische Instrumente AG
Studbachstrasse 13
8340 Hinwil
Switzerland

Internet: www.swan.ch
E-mail: support@swan.ch

Document Status

Title:	AMI Silica Operator's Manual	
ID:	A-96.250.671	
Revision	Issue	
00	Nov. 2011	First edition
01	Nov.2013	Mainboard V2.4, update to firmware release 5.40
02	Okt. 2014	Update to firmware release 5.41, installation of 2nd sample stream option.
03	June 2016	Mainboard V2.5, update to firmware release 6.00
04	July 2020	Mainboard V2.6
05	May 2025	Introduction of "PeriClip V2 for AMI" pump

© 2025, Swan Analytische Instrumente AG, Switzerland, all rights reserved.

This manual applies to firmware V6.22 and higher.
The information contained in this document is subject to change without notice.

Table of Contents

1. Safety Instructions	6
1.1. Warning Notices	7
1.2. General Safety Regulations	9
1.3. Restrictions for Use	10
2. Product Description	11
2.1. Instrument Specification	16
2.2. Instrument Overview	18
3. Installation	19
3.1. Installation Checklist	19
3.2. Mounting of Instrument Panel	20
3.3. Install the Constant Head	21
3.4. Connect Sample and Waste	22
3.4.1 Sample Inlet	22
3.4.2 Sample Outlet	22
3.5. Install the 2nd Sample Stream Option	23
3.6. Install the AMI Sample Sequencer	26
3.6.1 Sample connection with 2nd sample stream	26
3.7. Electrical Connections	27
3.7.1 Connection Diagram	28
3.7.2 Power Supply	31
3.8. Relay Contacts	32
3.8.1 Input	32
3.8.2 Alarm Relay	32
3.8.3 Relay 1 and 2	33
3.9. Signal Outputs	35
3.9.1 Signal Output 1 and 2 (Current Outputs)	35
3.10. Interface Options	35
3.10.1 Signal Output 3	36
3.10.2 Profibus, Modbus Interface	36
3.10.3 HART Interface	37
3.10.4 USB Interface	37
4. Instrument Setup	38
4.1. Activate the Peristaltic Pump	38
4.2. Prepare Reagents	38
4.3. Establish Sample Flow	39
4.4. Programming	42

5. Operation	43
5.1. Function of the Keys	43
5.2. Measured Values and Symbols on the Display	44
5.3. Software Structure	46
5.4. Changing Parameters and Values	47
5.5. Grab Sample Measurement	48
6. Maintenance	49
6.1. Maintenance Schedule	49
6.2. Stop of Operation for Maintenance	49
6.3. Refill or Replace Reagents	50
6.4. Verification	53
6.5. Calibration	54
6.6. Cleaning the Flow Cell	55
6.6.1 Disassemble the Constant Head	55
6.7. Cleaning the Photometer	57
6.8. Cleaning the solenoid valve	58
6.9. Tube Replacement	60
6.9.1 Replace the Pump Tubes	60
6.9.2 Tube Numbering	62
6.10. Fill or Flush Reagent System	63
6.11. Longer Stop of Operation	63
7. Troubleshooting	64
7.1. Slope Error	64
7.2. Grab Sample	66
7.3. Error List	67
7.4. Electrical Connections Inside the Peristaltic Pump	71
7.5. Replacing Fuses	73
8. Program Overview	74
8.1. Messages (Main Menu 1)	74
8.2. Diagnostics (Main Menu 2)	75
8.3. Maintenance (Main Menu 3)	76
8.4. Operation (Main Menu 4)	76
8.5. Installation (Main Menu 5)	77
9. Program List and Explanations	79
1 Messages	79
2 Diagnostics	79
3 Maintenance	81
4 Operation	82
5 Installation	83

10. Material Safety Data Sheets	98
10.1. Reagents	98
11. Default Values	99
12. Index	101
13. Notes	103

Operator's Manual

This document describes the main steps for instrument setup, operation and maintenance.

1. Safety Instructions

General The instructions included in this section explain the potential risks associated with instrument operation and provide important safety practices designed to minimize these risks.
If you carefully follow the information contained in this section, you can protect yourself from hazards and create a safer work environment.

More safety instructions are given throughout this manual, at the respective locations where observation is most important. Strictly follow all safety instructions in this publication.

Target audience Operator: Qualified person who uses the equipment for its intended purpose.
Instrument operation requires thorough knowledge of applications, instrument functions and software program as well as all applicable safety rules and regulations.

OM location Keep the AMI Operator's Manual in proximity of the instrument.

Qualification, training To be qualified for instrument installation and operation, you must:

- ◆ read and understand the instructions in this manual as well as the Material Safety Data Sheets.
- ◆ know the relevant safety rules and regulations.

1.1. Warning Notices

The symbols used for safety-related notices have the following meaning:



DANGER

Your life or physical wellbeing are in serious danger if such warnings are ignored.

- ◆ Follow the prevention instructions carefully.



WARNING

Severe injuries or damage to the equipment can occur if such warnings are ignored.

- ◆ Follow the prevention instructions carefully.



CAUTION

Damage to the equipment, minor injury, malfunctions or incorrect process values can be the consequence if such warnings are ignored.

- ◆ Follow the prevention instructions carefully.

Mandatory signs

The mandatory signs in this manual have the following meaning:



Safety goggles



Safety gloves

Warning signs The warning signs in this manual have the following meaning:



Electrical shock hazard



Corrosive



Harmful to health



Flammable



Warning general



Attention general

1.2. General Safety Regulations

Legal requirements

The user is responsible for proper system operation. All precautions must be followed to ensure safe operation of the instrument.

Spare parts and disposables

Use only official SWAN spare parts and disposables. If other parts are used during the normal warranty period, the manufacturer's warranty is voided.

Modifications

Modifications and instrument upgrades shall only be carried out by an authorized Service Technician. SWAN will not accept responsibility for any claim resulting from unauthorized modification or alteration.

WARNING

Electrical Shock Hazard



If proper operation is no longer possible, the instrument must be disconnected from all power lines, and measures must be taken to prevent inadvertent operation.

- ◆ To prevent from electrical shock, always make sure that the ground wire is connected.
- ◆ Service shall be performed by authorized personnel only.
- ◆ Whenever electronic service is required, disconnect instrument power and power of devices connected to.
 - relay 1,
 - relay 2,
 - alarm relay

WARNING



For safe instrument installation and operation you must read and understand the instructions in this manual.

WARNING



Only SWAN trained and authorized personnel shall perform the tasks described in this document.

1.3. Restrictions for Use

The sample must not contain any particles, which may block the flow cell. Sufficient sample flow is coercive for the correct function of the instrument.



WARNING

For safe instrument installation and operation you must read and understand the instructions in this manual, as well as the Material Safety Data Sheets (MSDS).

- ◆ Reagent 1: Ammoniummolybdate consists of:
 - Reagent 1a: Ammonium molybdate tetrahydrate
 - Reagent 1b: Sodium hydroxide pellets
- ◆ Reagent 2: Sulfuric acid 25%
- ◆ Reagent 3: Oxalic acid
- ◆ Reagent 4: Ammonium ferrous sulfate consists of:
 - Reagent 4a: Sulfuric acid 25%
 - Reagent 4b: Ammonium iron (II) sulfate hexahydrate
- ◆ Silica Standard 100 ppm 100 ml

Download MSDS

The current Material Safety Data Sheets (MSDS) for the above listed Reagents are available for downloading at www.swan.ch.

2. Product Description

Application range	The AMI Silica is a complete monitoring system for the automatic, continuous measurement of the silica content in water of power plants or demineralizer plants.
Silica measurement	<p>The determination of silica is done by the photometric analysis of molybdate blue at 810 nm.</p> <p>Silica and ortho-phosphates react at low pH with ammonium molybdate to the yellow colored silico molybdic acid respectively phospho molybdic acid. The phospho molybdic acid is destroyed with oxalic acid before the silico molybdic acid is reduced with ammonium iron(II) sulfate to the heteropoly-blue complex.</p> <p>The required reagents are added in 3 steps to the sample in the photometer, where they allow a precise measurement of the silica content in the sample once the chemical reaction is complete.</p>
Grab sample	The grab sample measuring mode allows the measurement of samples from remote locations.
Second sample stream	If required the AMI Silica can be equipped with the optional second sample stream module.
Sample sequencer	If measurement of more than two sample streams is required, the AMI Silica can be connected to a Sample Sequencer, which allows to measure up to six sample streams.
Signal outputs	<p>Two signal outputs programmable for measured values (freely scalable, linear or bilinear) or as continuous control output (control parameters programmable).</p> <p>Current loop: 0/4–20 mA Maximal burden: 510 Ω</p> <p>Third signal output available as an option. The third signal output can be operated as a current source or as a current sink (selectable via switch).</p>
Relays	<p>Two potential-free contacts programmable as limit switches for measuring values, controllers or timer for system cleaning with automatic hold function. Both contacts can be used as normally open or normally closed.</p> <p>Maximum load: 1 A / 250 VAC</p>

- Alarm relay** One potential free contact.
Alternatively:
- ◆ Open during normal operation, closed on error and loss of power.
 - ◆ Closed during normal operation, open on error and loss of power.
- Summary alarm indication for programmable alarm values and instrument faults.
- Input** For potential-free contact to freeze the measuring value or to interrupt control in automated installations (hold function or remote-off).
- Safety features** No data loss after power failure. All data is saved in non-volatile memory. Overvoltage protection of inputs and outputs. Galvanic separation of measuring inputs from signal outputs.
- Communication interface (optional)**
- ◆ USB Interface for logger download
 - ◆ Third signal output (can be used in parallel to the USB interface)
 - ◆ RS485 with Fieldbus protocol Modbus or Profibus DP
 - ◆ HART interface
- Fluidics** The sample flows via the sample inlet [R] and the flow regulating valve [Q] into the constant head [A]. Adjust the flow regulating valve so that always a small part of the sample flows through the overflow tube [B] into the waste [I]. This adjustment ensures a sufficient sample flow through the measuring chamber of the photometer [F]. If no measurement takes place, the sample flows through the photometer outlet [E] where it will be aerated through air inlet [S] to generate bubbles. Then the sample flows through the bubble counter [H] into the waste [I].
- If a measurement cycle starts, the solenoid valve [C] is activated and the sample inlet [D] to the photometer is closed. The 6-way valve [N] is automatically rotated to position 1 and a precisely defined quantity reagent of the canister [J] is pumped into the measuring chamber by the peristaltic pump [O]. Immediately after that the 6-way valve is rotated in position 2 and the reagent 2 from canister [K] is pumped into the photometer and mixed with the reagent 1 and the sample by the magnetic stirrer [G]. This procedure is repeated with the 6-way valve in position 3 and reagent 3 [L] and 6-way valve in position 4 and reagent 4 [M].
- After the measurement has been finished, the solenoid valve opens and the measuring chamber is flushed.
Position 6 of the 6-way valve is not used.

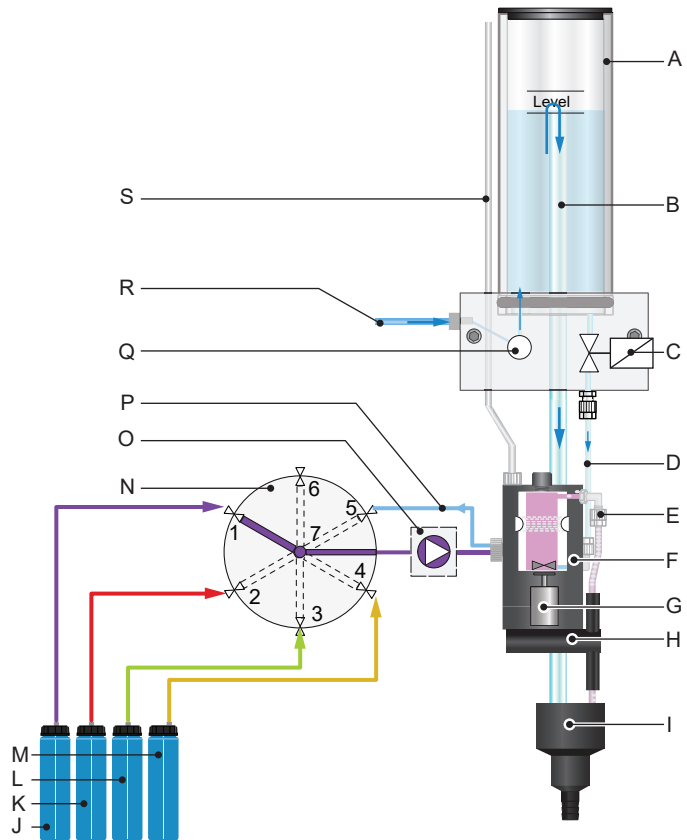

- | | |
|----------------------------------|--------------------------------|
| A Constant head | K Reagent 2 |
| B Overflow tube | L Reagent 3 |
| C Solenoid valve | M Reagent 4 |
| D Sample inlet photometer | N 6-way valve |
| E Sample outlet | O Peristaltic pump |
| F Photometer | P Loop |
| G Magnetic stirrer | Q Flow regulating valve |
| H Bubble counter | R Sample inlet |
| I Waste | S Air Inlet |
| J Reagent 1 | |

- Measurement cycle** The quantities of the reagents are precisely defined by a certain number of rotations of the peristaltic pump. After the predefined quantity of a reagent has been sucked from the canister, the 6-way valve is rotated to position 5, where sample from the photometer is sucked into the loop [P]. With the sample in the tube the reagents are pumped into the photometer.
- The measurement of the sample is carried out as follows:
The sample flows via constant head through the photometer. If a measuring cycle starts:
- 1 The sample inlet is closed by activation of the solenoid valve [C]. A zero measurement is performed.
 - 2 6-way valve in position 1:
the reagent 1 is sucked from the canister [J].
 - 3 6-way valve in position 2:
the reagent 2 is sucked from the canister [K].
 - 4 6-way valve in position 5:
sample is sucked into the loop, the whole quantity of the reagents is pushed into the photometer.
 - 5 The reagents are mixed with the magnetic stirrer, the first reaction starts.
- After 150 sec:
- 6 6-way valve in position 3:
the reagent 3 is sucked from the canister [L].
 - 7 6-way valve in position 5:
sample is sucked into the loop, the whole quantity of the reagent is pushed into the photometer.
 - 8 The reagents are mixed with the magnetic stirrer, the second reaction starts.
- After 90 sec:
- 9 6-way valve in position 4:
the reagent 4 is sucked from the canister [M].
 - 10 6-way valve in position 5:
sample is sucked into the loop, the whole quantity of the reagent is pushed into the photometer.
 - 11 The reagents are mixed with the magnetic stirrer, the third reaction starts.
- After 90 sec:
- 12 The sample measurement is performed.
 - 13 The sample inlet is opened by deactivation of the solenoid valve.
⇒ *The measuring cell of the photometer is flushed.*
 - 14 6-way valve in position 5:
The reagent inlet tube is flushed with sample.

⇒ The peristaltic pump rotates for a certain time. The reagent free sample in the photometer is sucked into the reagent pipe and then via loop pumped back into the photometer.

A measuring cycle takes 10 minutes.
The diagram below shows the process of a measuring cycle in the time axis.

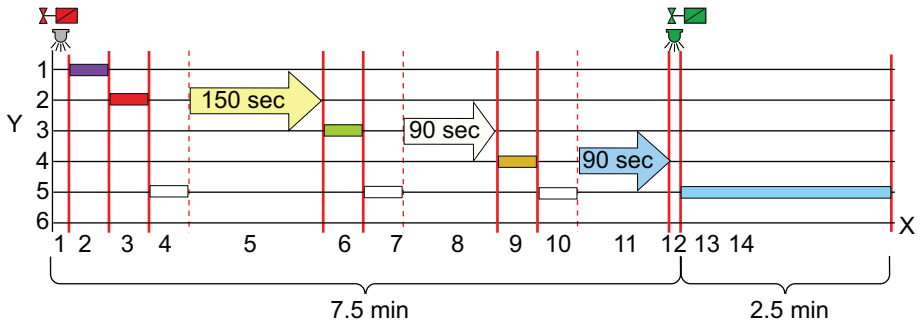

- | | | | |
|----------|------------------------------|--|---------------|
| X | Measuring steps on time axis | | Reagent 2 |
| Y | 6-way valve position | | Reagent 3 |
| | Solenoid valve closed | | Reagent 4 |
| | Solenoid valve open | | Loop |
| | Zero point measurement | | Reaction time |
| | Sample measurement | | Flush loop |
| | Reagent 1 | | |

2.1. Instrument Specification

Power supply	AC variant:	100–240 VAC ($\pm 10\%$) 50/60 Hz ($\pm 5\%$)
	DC variant	10–36 VDC
	Power consumption:	max. 35 VA
Transmitter specifications	Housing:	aluminum, with a protection degree of IP 66 / NEMA 4X
	Ambient temperature:	-10 to +50 °C
	Storage and transport:	-30 to +85 °C
	Humidity:	10–90% rel., non condensing
	Display:	backlit LCD, 75 x 45 mm
Sample requirements	Flow rate:	min. 10 l/h
	Sample pressure inlet:	0.15–2 bar (2–28 PSI)
	Temperature:	up to 50 °C (122 °F)

Note: *No oil, no grease, no sand.*

Silica measurement	Measuring method:	colorimetric, molybdosilicate method
	Measuring range:	1 to 5'000 ppb
	Reproducibility:	± 1 ppb or $\pm 5\%$ whichever is greater
	Max. PO ₄ concentration:	<10 ppm

On-site requirements	The analyzer site must permit connections to:	
	Sample inlet:	Tube 4 x 6 mm
	1 drain:	Tube 15 x 20 mm (1/2") hose nozzle which must end in pressure free waste of sufficient capacity.

Dimensions

Panel:	stainless steel
Dimensions:	400 x 850 x 160 mm
Screw diameter:	8 mm
Weight:	16.0 kg

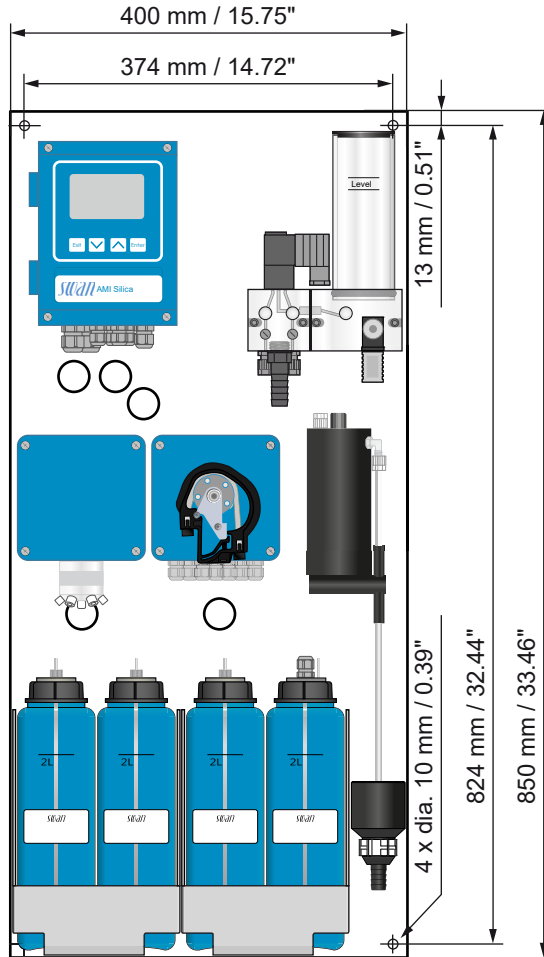

2.2. Instrument Overview

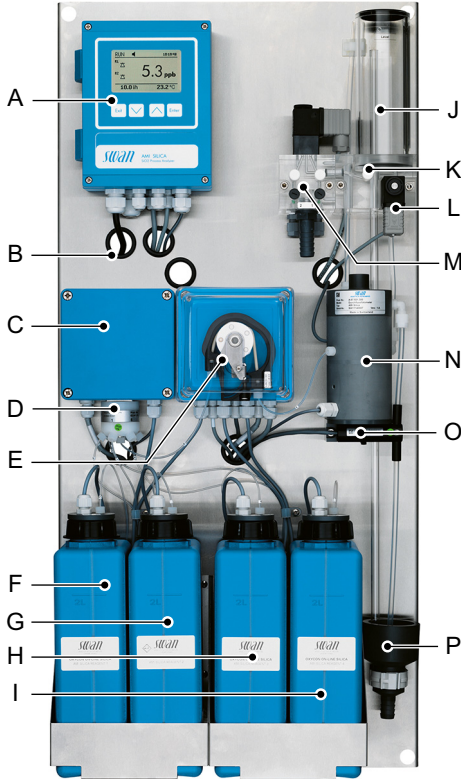

- | | |
|----------------------------------|---|
| A Transmitter | K Flow regulating valve |
| B Panel | L Solenoid valve |
| C 6-way valve control box | M Sample inlet with sample switch (2nd sample stream option) |
| D 6-way valve | N Photometer with magnetic stirrer |
| E Peristaltic pump | O Bubble counter |
| F Reagent 1 | P Waste |
| G Reagent 2 | |
| H Reagent 3 | |
| I Reagent 4 | |
| J Constant head | |

3. Installation

3.1. Installation Checklist

On-site requirements	AC variant: 100–240 VAC ($\pm 10\%$), 50/60 Hz ($\pm 5\%$) DC variant: 10–36 VDC Power consumption: 35 VA maximum. Protective earth connection required. Sample line with sufficient sample flow and pressure (see Instrument Specification , p. 16).
Installation	Mounting of Instrument Panel , p. 20. Install the Constant Head , p. 21. Connect Sample and Waste , p. 22.
Electrical wiring	Connect all external devices like limit switches, current loops and pumps. Install the 2nd Sample Stream Option , p. 23 (if available). Install the AMI Sample Sequencer , p. 26 (if available). Connect the power cord, see Power Supply , p. 31.
Reagents	Prepare the reagents, see Refill or Replace Reagents , p. 50. Insert suction lances, see Instrument Setup , p. 38.
Power-up	Activate the Peristaltic Pump , p. 38. Prepare Reagents , p. 38. Establish Sample Flow , p. 39. Switch on power.
Instrument setup	Program all parameters for external devices (interface, recorders, etc.). Program all parameters for instrument operation (limits, alarms, measuring interval).
Run-in period	Let the instrument run continuously for 1 h.



3.2. Mounting of Instrument Panel

The first part of this chapter describes the preparing and placing of the system for use.

- ◆ The instrument must only be installed by trained personnel.
- ◆ Mount the instrument in vertical position.
- ◆ For ease of operation mount it so that the display is at eye level.
- ◆ For the installation a kit containing the following installation material is available:
 - 4 Screws 8x70 mm
 - 4 Dowels
 - 4 Washers 8.4/24 mm

**Mounting re-
quirements**

The instrument is only intended for indoor installation.
For dimensions see [p. 17](#).

3.3. Install the Constant Head

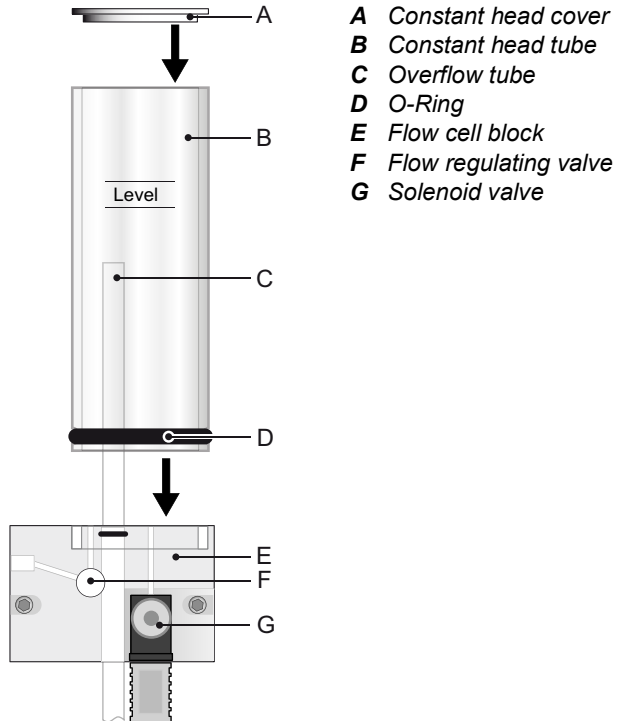

- 1 Push the overflow tube [C] through the flow cell block [E] as far as it ends the waste funnel.
- 2 Fit the constant head tube [B] into the flow cell block [E].
- 3 Put the constant head cover [A] onto the constant head tube.
- 4 Adjust the overflow tube [C] so that it is at the lower level mark.

3.4. Connect Sample and Waste

3.4.1 Sample Inlet

Use plastic tube (FEP, PA, or PE 4 x 6 mm) to connect the sample line.

Mounting of SERTO fitting

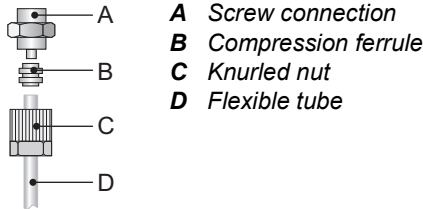

3.4.2 Sample Outlet

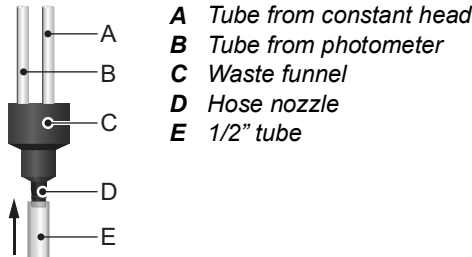

Connect the 1/2" tube [E] to the hose nozzle [D] and place it into a pressure free drain with sufficient capacity.

3.5. Install the 2nd Sample Stream Option

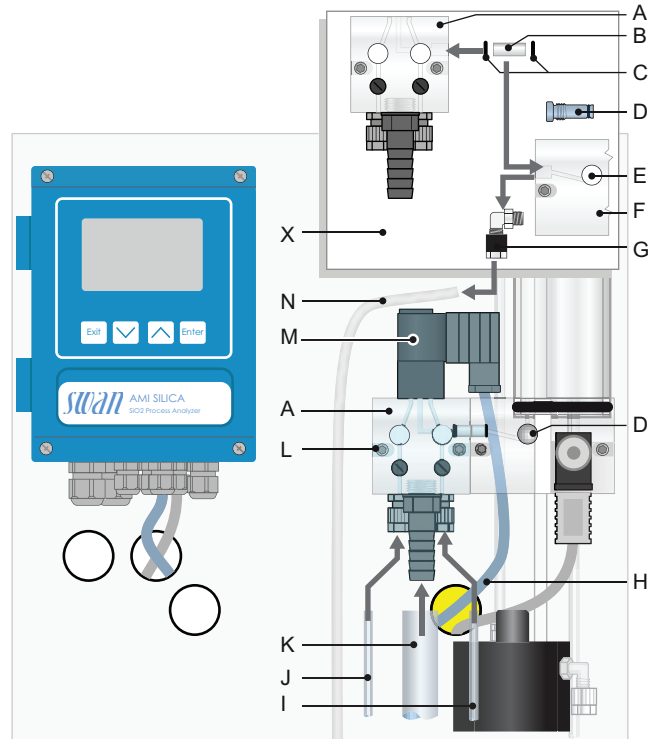

- | | |
|-------------------------------------|----------------------------|
| A Block housing | I Sample stream 1 |
| B Connecting piece | J Sample stream 2 |
| C 2 O-rings | K Waste (15x20 mm) |
| D Blind Plug | L Fixing screws |
| E Flow regulating valve | M Solenoid valve |
| F Flow cell block | N Sample inlet tube |
| G Sample inlet (Elbow union) | X Detail view |
| H Solenoid valve cable | |

- 1 Stop operation according to [Stop of Operation for Maintenance, p. 49.](#)
- 2 Close the main sample tap.

- 3** Unscrew and remove the flow regulating valve [E] from the flow cell block [F].
- 4** Screw the blind plug [D] into the flow cell block.
- 5** Remove the sample inlet tube [N] from the sample inlet (elbow union) [G].
- 6** Remove the elbow union from the flow cell block.
- 7** Put one of the O-rings [C] into the bore of the block housing [A] and the other one into the bore of the flow cell block [F].
- 8** Insert the connecting piece [B] into the bore of the flow cell block.
- 9** Slide the block housing [A] over the connecting piece and press it against the flow cell block [F] while screwing the block housing with the 2 fixing screws [L] onto the panel.
- 10** Push a 15 x 20 mm tube [K] (not included in the installation set) over the ½" hose nozzle of the block housing and put the end of the tube into a pressure free drain.
- 11** Connect the sample stream 1 [I] and the sample stream 2 [J] to the corresponding sample inlets of the block housing according to section [Sample Inlet, p. 22](#).

**Connect the
solenoid valve**



WARNING

Electrical shock hazard!

Before opening the AMI transmitter switch power off.

Use one of the PG7 cable glands to feed the cable of the solenoid valve into the AMI transmitter housing.

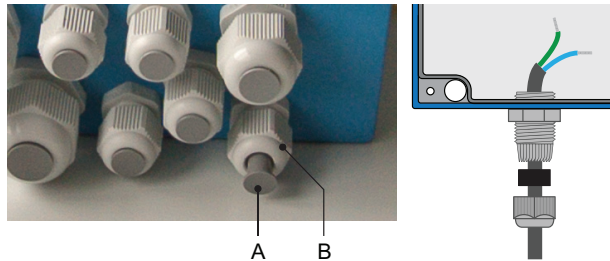

- 1 Remove the plug [A] from the cable gland [B].
- 2 Open the transmitter housing.
- 3 Feed the cable of the solenoid valve through the cable gland [B] into the AMI transmitter housing.
- 4 Connect the wires to the terminals in the AMI transmitter according to the connection diagram.



3.6. Install the AMI Sample Sequencer

If more than two sample streams are required, an AMI Sample Sequencer can be connected to the AMI Silica, which allows to measure up to six sample streams. The electrical connection is described in the manual of the AMI Sample Sequencer.

3.6.1 Sample connection with 2nd sample stream

If an AMI Sample Sequencer is connected to an AMI Silica with a second sample stream option [A], sample inlet 2 will be automatically switched off and only sample inlet 1 will be active.

Connect the sample outlet of the Sample Sequencer to sample inlet 1 [E] of the second sample stream option.

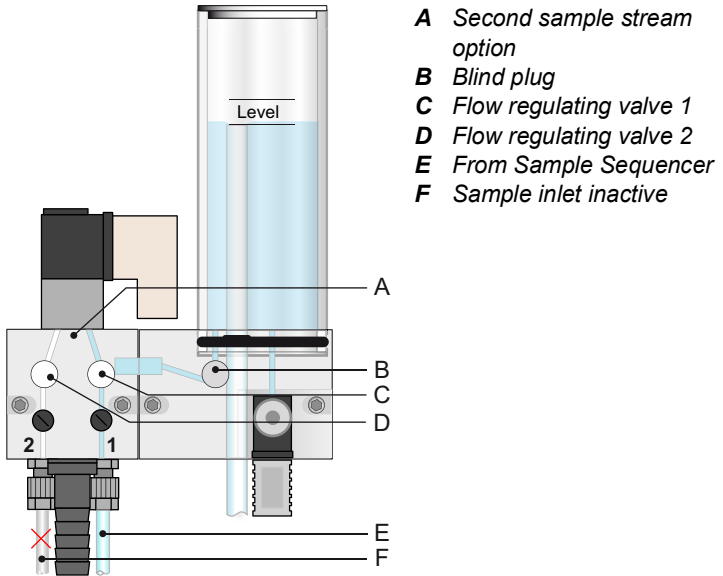

3.7. Electrical Connections



WARNING

Risk of electrical shock

Do not perform any work on electrical components if the transmitter is switched on. Failure to follow safety instructions could result in serious injury or death.

- ♦ Always turn off power before manipulating electric parts.
- ♦ Grounding requirements: Only operate the instrument from a power outlet which has a ground connection.
- ♦ Make sure the power specification of the instrument corresponds to the power on site.

Cable thicknesses

In order to comply with IP66, use the following cable thicknesses

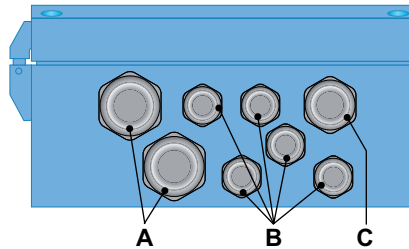

A PG 11 cable gland: cable \varnothing_{outer} 5–10 mm

B PG 7 cable gland: cable \varnothing_{outer} 3–6.5 mm

C PG 9 cable gland: cable \varnothing_{outer} 4–8 mm

Note: Protect unused cable glands

Wire

- ♦ For power and relays: Use max. 1.5 mm² / AWG 14 stranded wire with end sleeves.
- ♦ For signal outputs and input: Use 0.25 mm² / AWG 23 stranded wire with end sleeves.



WARNING

External voltage

Externally supplied devices connected to relay 1 or 2 or to the alarm relay can cause electrical shocks.

- ◆ Make sure that the devices connected to the following contacts are disconnected from the power before resuming installation.
 - relay 1
 - relay 2
 - alarm relay



WARNING

To prevent from electrical shock, do not connect the instrument to the power unless the ground wire (PE) is connected.



WARNING

The mains of the transmitter must be secured by a main switch and appropriate fuse or circuit breaker.

3.7.1 Connection Diagram

There are two versions of the peristaltic pump that can be used with the AMI Silica. The terminal assignment inside the pump differs depending on the version. This manual therefore contains two separate connection diagrams:

- ◆ AMI Silica with “PeriClip V2 for AMI” pump: see [p. 29](#),
- ◆ AMI Silica with “PeriClip” pump: see [p. 30](#).

Check the type label of the peristaltic pump to see which version is installed.

AMI Silica with “PeriClip V2 for AMI” Pump

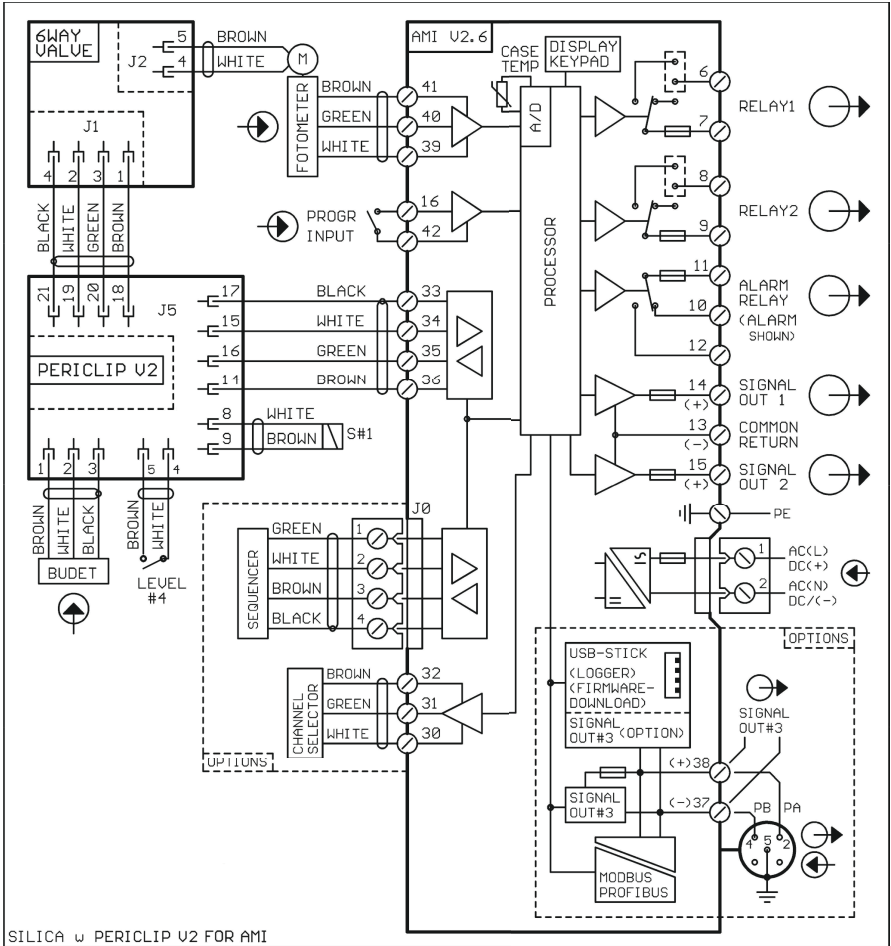

SILICA w PERICLIP V2 FOR AMI

CAUTION



Use only the terminals shown in this diagram, and only for the mentioned purpose. Use of any other terminals will cause short circuits with possible corresponding consequences to material and personnel.

AMI Silica with “PeriClip” Pump

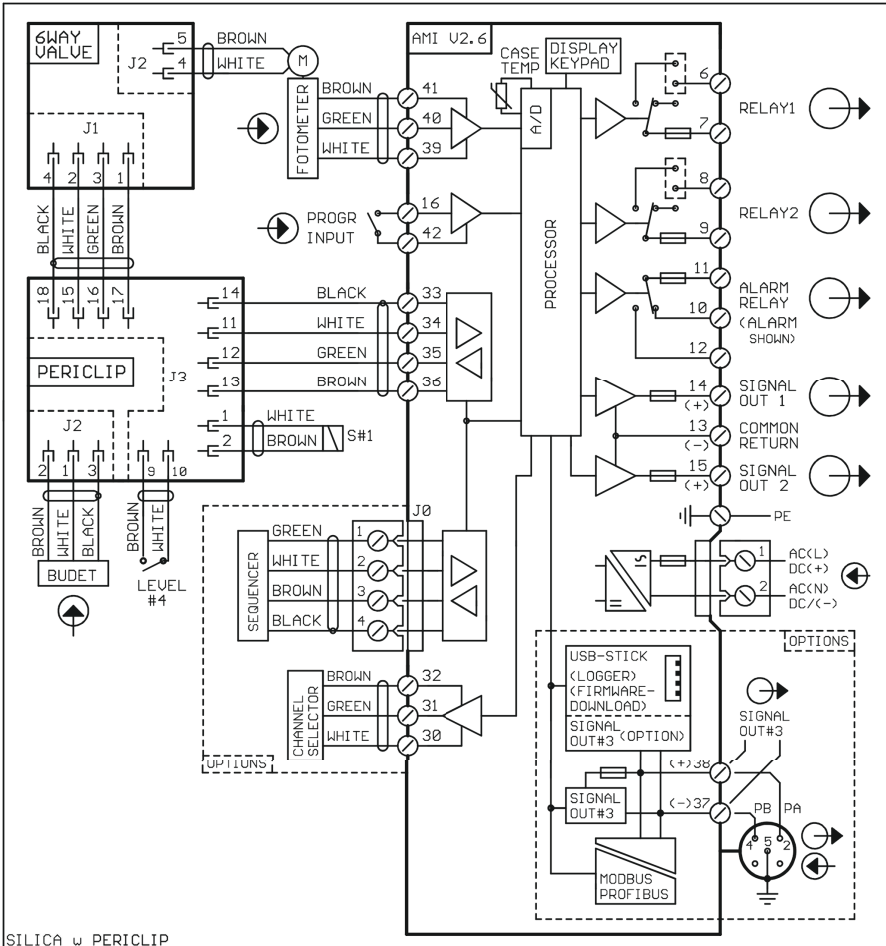

SILICA w PERICLIP

CAUTION



Use only the terminals shown in this diagram, and only for the mentioned purpose. Use of any other terminals will cause short circuits with possible corresponding consequences to material and personnel.

3.7.2 Power Supply



WARNING

Electrical shock hazard

Installation and maintenance of electrical parts must be performed by professionals. Always turn off power before manipulating electric parts.

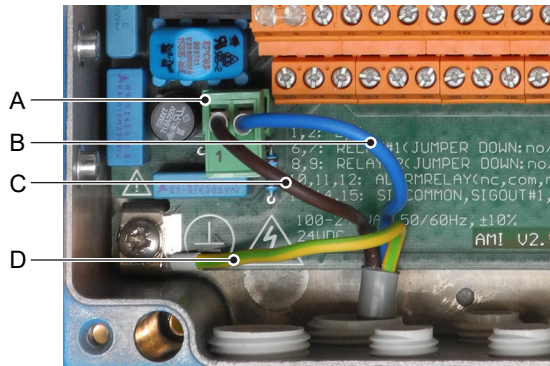

- A Power supply connector
- B Neutral(-) conductor, terminal 2
- C Phase(+) conductor, terminal 1
- D Protective earth PE

Note: The protective earth wire (ground) has to be connected to the grounding terminal.

Installation requirements

The installation must meet the following requirements.

- ♦ Mains cable to comply with standards IEC 60227 or IEC 60245; flammable rating FV1
- ♦ Mains equipped with an external switch or circuit-breaker
 - near the instrument
 - easily accessible to the operator
 - marked as interrupter for AMI Silica

3.8. Relay Contacts

3.8.1 Input

Note: Use only potential-free (dry) contacts.

The total resistance (sum of cable resistance and resistance of the relay contact) must be less than 50 Ω.

If signal output is set to hold, measurement is interrupted if input is active.

For programming see menu 5.3.4, p. 95.

3.8.2 Alarm Relay

Note: Max. load 1 A (time-lag) / 250 VAC

Alarm output for system errors.

Error codes see [Troubleshooting](#), p. 64

Programming see menu 5.3.1, p. 89

Note: With certain alarms and certain settings of the AMI transmitter the alarm relay does not switch. The error, however, is shown on the display.

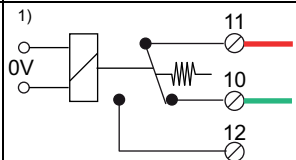
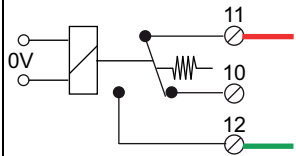
	Terminals	Description	Relay connection
NC ¹⁾ Normally Closed	10/11	Active (opened) during normal operation. Inactive (closed) on error and loss of power.	
NO Normally Open	12/11	Active (closed) during normal operation. Inactive (opened) on error and loss of power.	

1) usual use

3.8.3 Relay 1 and 2

Note: Max. load 1 A/250 VAC

Relay 1 and 2 can be configured as normally open or as normally closed. Standard for both relays is normally open. To configure a relay as normally closed, set the jumper in the upper position.

Note: Some error codes and the instrument status may influence the status of the relays described below.

Relay config.	Terminals	Jumper pos.	Description	Relay configuration
Normally Open	6/7: Relay 1 8/9: Relay 2		Inactive (opened) during normal operation and loss of power. Active (closed) when a programmed function is executed.	
Normally Closed	6/7: Relay 1 8/9: Relay 2		Inactive (closed) during normal operation and loss of power. Active (opened) when a programmed function is executed.	

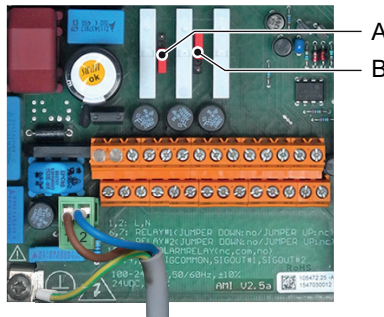

A Jumper set as normally open (standard setting)

B Jumper set as normally closed

For programming see Menu Installation [5.3.2](#) and [5.3.3](#), p. 90



CAUTION

Risk of damage of the relays in the AMI transmitter due to heavy inductive load.

Heavy inductive or directly controlled loads (solenoid valves, dosing pumps) may destroy the relay contacts.

- ◆ To switch inductive loads > 0.1 A use an AMI relay box available as an option or suitable external power relays.

Inductive load

Small inductive loads (max 0.1 A) as for example the coil of a power relay can be switched directly. To avoid noise voltage in the AMI Transmitter it is mandatory to connect a snubber circuit in parallel to the load.

A snubber circuit is not necessary if an AMI relaybox is used.

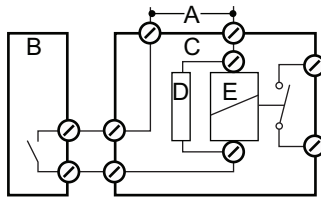

- A** AC or DC power supply
- B** AMI Transmitter
- C** External power relay
- D** Snubber
- E** Power relay coil

Resistive load

Resistive loads (max. 1 A) and control signals for PLC, impulse pumps and so on can be connected without further measures

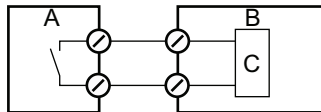

- A** AMI Transmitter
- B** PLC or controlled pulse pump
- C** Logic

Actuators

Actuators, like motor valves, are using both relays: One relay contact is used for opening, the other for closing the valve, i.e. with the 2 relay contacts available, only one motor valve can be controlled. Motors with loads bigger than 0.1 A must be controlled via external power relays or an AMI relay box.

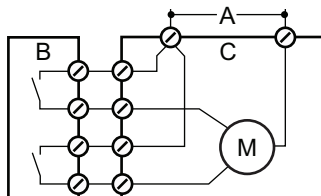

- A** AC or DC power supply
- B** AMI Transmitter
- C** Actuator

3.9. Signal Outputs

3.9.1 Signal Output 1 and 2 (Current Outputs)

Note: Max. burden 510 Ω .

If signals are sent to two different receivers, use signal isolator (loop isolator).

Signal output 1: Terminals 14 (+) and 13 (-)

Signal output 2: Terminals 15 (+) and 13 (-)

Programming see menu [5.2 Signal Outputs](#), p. 85.

3.10. Interface Options

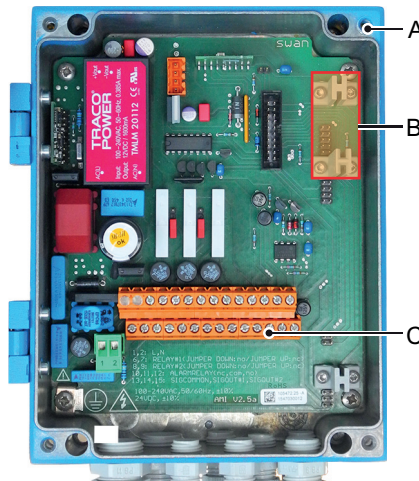

- A** AMI Transmitter
- B** Slot for interfaces
- C** Screw terminals

The slot for interfaces can be used to expand the functionality of the AMI instrument with either:

- ◆ an additional signal output
- ◆ a Profibus or Modbus connection
- ◆ a HART connection
- ◆ an USB Interface

3.10.1 Signal Output 3

Terminal 38 (+) and 37 (-).

Requires the additional board for the third signal output 0/4–20 mA. The third signal output can be operated as a current source or as a current sink (switchable via switch [A]). For detailed information see the corresponding installation instruction.

Note: Max. burden 510 Ω .

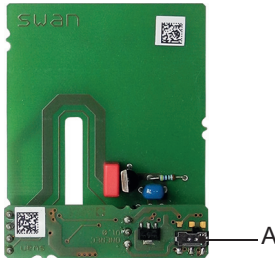

Third signal output 0/4–20 mA PCB

A Operating mode selector switch

3.10.2 Profibus, Modbus Interface

Terminal 37 PB, Terminal 38 PA

To connect several instruments by means of a network or to configure a PROFIBUS DP or a MODBUS connection, consult the PROFIBUS/MODBUS manual. Use appropriate network cable.

Note: The switch must be ON, if only one instrument is installed, or on the last instrument in the bus.

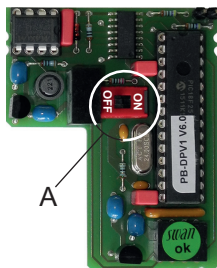

Profibus, Modbus Interface PCB (RS 485)

A On - OFF switch

3.10.3 HART Interface

Terminals 38 (+) and 37 (-).

The HART interface PCB allows for communication via the HART protocol. For detailed information, consult the HART manual.

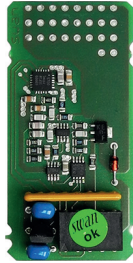

HART Interface PCB

3.10.4 USB Interface

The USB Interface is used to store Logger data and for Firmware upload. For detailed information see the corresponding installation instruction.

The optional third signal output 0/4 – 20 mA PCB [B] can be plugged onto the USB interface and used in parallel.

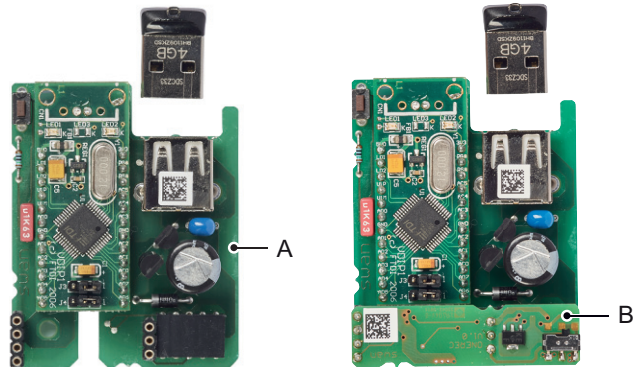

USB Interface

A USB Interface PCB

B Third signal output 0/4 - 20 mA PCB

4. Instrument Setup

4.1. Activate the Peristaltic Pump

The occlusion frames of the peristaltic pump are opened during transport and storage. This prevents the pump tubes from sticking together at the pressure points.

- 1 Turn the occlusion frame [B] clockwise to activate the peristaltic pump.

⇒ *The peristaltic pump is ready.*

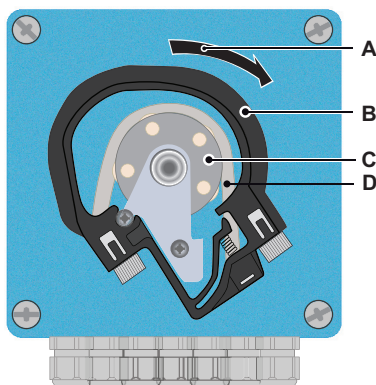

- A** Turn clockwise to activate
- B** Occlusion frame
- C** Rotor
- D** Pump tube

4.2. Prepare Reagents

See [Refill or Replace Reagents](#), p. 50.

- 1 Insert the suction lances into the canisters.

⇒ *Make sure that the numbers on the suction lances correspond to the numbers on the canisters.*

4.3. Establish Sample Flow



CAUTION

Pollution of the reagents

If the occlusion frames are not closed, sample may flow into the reagents.

- ◆ Lock the occlusion frames before establishing the sample flow.

Single-channel instrument

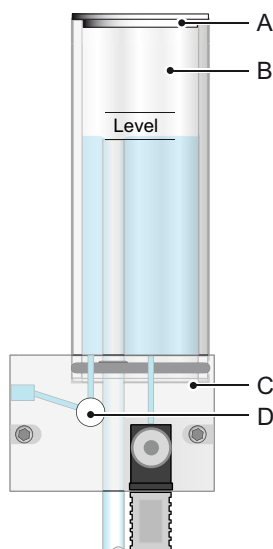

- A** Cover
- B** Outer tube
- C** Flow cell block of the constant head
- D** Flow regulating valve

With a single-channel instrument, proceed as follows:

- 1 Switch on power.
- 2 Adjust the sample flow using the flow regulating valve [D] on the flow cell block of the constant head.
- 3 Start <Fill system>, see [Fill or Flush Reagent System, p. 63](#).
- 4 Check tube connections and flow cell for leaks and repair if necessary.
- 5 Let the instrument run-in for one hour.



**Two-channel
instrument**

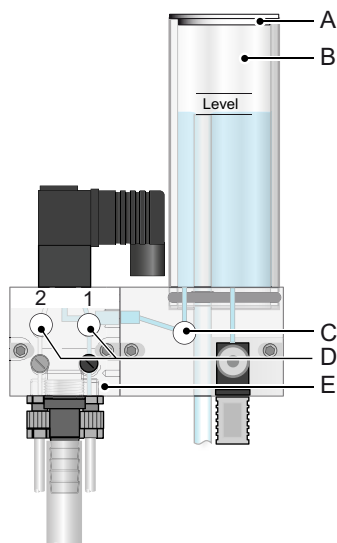

- A** Cover
- B** Outer tube
- C** Blind plug
- D** Flow regulating valves
- E** Second sample stream option

If the second sample stream option is installed, proceed as follows:

- 1** Switch on power.
- 2** Adjust the sample flow using the flow regulating valves [D] of the second sample stream option.
- 3** Start <Fill system>, see [Fill or Flush Reagent System](#), p. 63.
- 4** Check tube connections and flow cell for leaks and repair if necessary.
- 5** Let the instrument run-in for one hour.

**Instrument
with AMI Sam-
ple Sequencer**

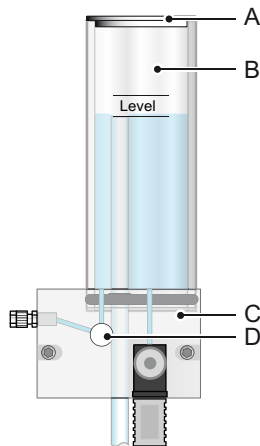

- A** Cover
- B** Outer tube
- C** Flow cell block of the constant head
- D** Flow regulating valve

If an AMI Sample Sequencer is installed, proceed as follows:

- 1** Switch on power.
- 2** Open the flow regulating valve [D] on the flow cell block of the constant head.
- 3** Adjust the sample flow using the flow regulating valves [F] of the AMI Sample Sequencer.

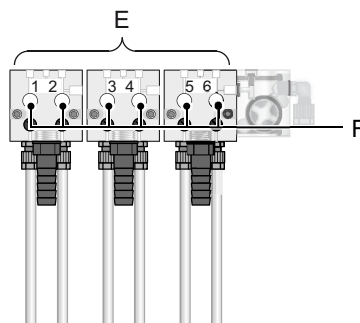

- E** Flow cell blocks of sample streams 1–6
- F** Flow regulating valves

- 4** Start <Fill system>, see [Fill or Flush Reagent System, p. 63](#).
- 5** Check tube connections and flow cell for leaks and repair if necessary.
- 6** Let the instrument run-in for one hour.

4.4. Programming

External devices Program all parameters for external devices (interface, recorders, etc.). See [5.2 Signal Outputs, p. 85](#) and [5.3 Relay Contacts, p. 89](#).

Limits, alarms Program all parameters for instrument operation (limits, alarms). See [5.3 Relay Contacts, p. 89](#).

Multi-channel instruments If the 2nd sample stream option is installed, make the following settings:

- ♦ Set the number of channels to “2”. See [5.1.5, p. 83](#).
- ♦ Select the channel switching mode. See [5.1.6, p. 84](#).

If an AMI Sample Sequencer is installed, make the following settings:

- ♦ On the AMI Sample Sequencer, navigate to <Installation>/<Sequence> and select “AMI”.
- ♦ On the AMI Silica, select the number of available channels and the channel selection mode. See [5.1.5, p. 83](#) and [5.1.6, p. 84](#).

For detailed descriptions of the channel selection modes, see the following sections:

- [Mode Internal, p. 84](#)
- [Mode Fieldbus, p. 84](#)
- [Mode External, p. 84](#)

5. Operation

5.1. Function of the Keys

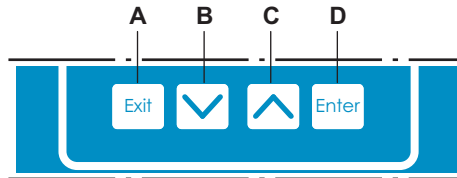

- A** to exit a menu or command (rejecting any changes)
to move back to the previous menu level
- B** to move DOWN in a menu list and to decrease digits
- C** to move UP in a menu list and to increase digits
to scroll the measuring values if a Sample Sequencer is connected
- D** to open a selected sub-menu
to accept an entry

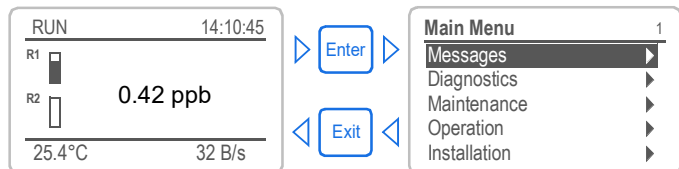

Program Access, Exit





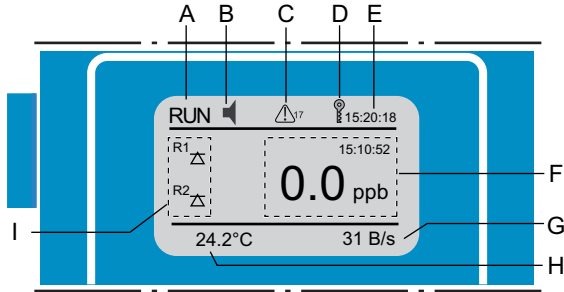







5.2. Measured Values and Symbols on the Display

Display when
operating with
one sample
stream





- A** RUN normal operation
 HOLD input closed or cal delay: Instrument on hold (shows status of signal outputs).
 OFF input closed: control/limit is interrupted (shows status of signal outputs).
- B** ERROR  Error  Fatal error
- C** Reagent low
- D** Transmitter control via Profibus
- E** Time
- F** Process values with time stamp
- G** Sample flow in bubbles per second
- H** Sample temperature
- I** Relay status

Relay status, symbols

-   upper/lower limit not yet reached
  upper/lower limit reached
 control upw./downw. no action
 control upw./downw. active, dark bar indicates control intensity
 motor valve closed
 motor valve: open, dark bar indicates approx. position
 timer
 timer: timing active (hand rotating)

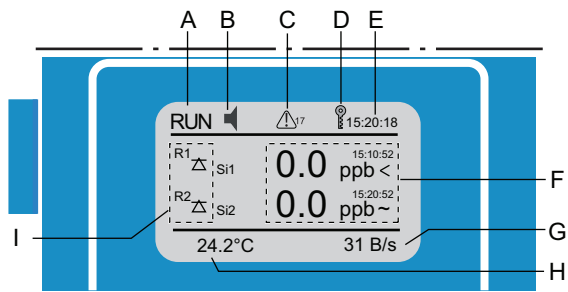
Display when
operating with
two sample
streams



- A** RUN normal operation
- HOLD input closed or cal delay: Instrument on hold
 (shows status of signal outputs).
- OFF input closed: control/limit is interrupted (shows
 status of signal outputs).
- B** ERROR  Error  Fatal error
- C** Reagent low
- D** Transmitter control via Profibus
- E** Time
- F** Process values with time stamp
 Si1 sample stream 1
 Si2 sample stream 2
 < Channel active
 ~ No sample flow
 n Measurement not valid (not visible in this example)
 x Only visible if a Sample Sequencer is connected to the
 AMI Silica. Indicates that the sample stream is inactive.
- G** Sample flow in bubbles per second
- H** Sample temperature
- I** Relay status

5.3. Software Structure

Main Menu	1
Messages	▶
Diagnostics	▶
Maintenance	▶
Operation	▶
Installation	▶

Messages	1.1
Pending Errors	▶
Maintenance List	▶
Message List	▶

Menu Messages 1

Reveals pending errors as well as an event history (time and state of events that have occurred at an earlier point of time). It contains user relevant data.

Diagnostics	2.1
Identification	▶
Sensors	▶
Sample	▶
I/O State	▶
Interface	▶

Menu Diagnostics 2

Provides user relevant instrument and sample data.

Maintenance	3.1
Calibration	▶
Service	▶
Simulation	▶
Set Time	01.01.05 16:30:00

Menu Maintenance 3

For instrument calibration, relay and signal output simulation, and to set the instrument time. It is used by the service personnel.

Operation	4.1
Grab Sample	▶
Sensors	▶
Relay Contacts	▶
Logger	▶

Menu Operation 4

User relevant parameters that might need to be modified during daily routine. Normally password protected and used by the process-operator. Subset of menu 5 - Installation, but process-related.

Installation	5.1
Sensors	▶
Signal Outputs	▶
Relay Contacts	▶
Miscellaneous	▶
Interface	▶

Menu Installation 5

For initial instrument set up by SWAN authorized person, to set all instrument parameters. Can be protected by means of password.

5.4. Changing Parameters and Values

Changing parameters

The following example shows how to change the logger interval:

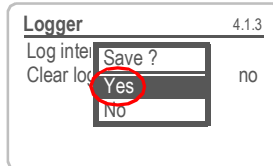
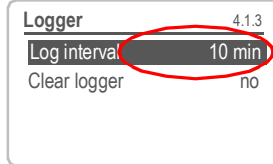
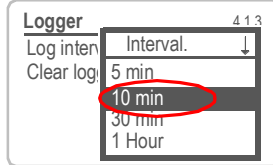
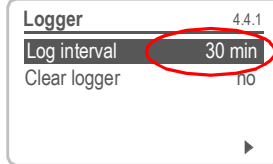

- 1 Select the parameter you want to change.
- 2 Press [Enter]
- 3 Press [] or [] key to highlight the required parameter.
- 4 Press [Enter] to confirm the selection or [Exit] to keep the previous parameter).

⇒ *The selected parameter is highlighted but not saved yet.*

- 5 Press [Exit].

⇒ *Yes is highlighted.*

- 6 Press [Enter] to save the new parameter.
- 7 *The system reboots, the new parameter is set.*

Changing values

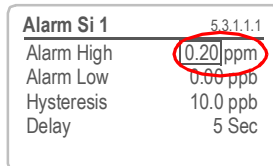
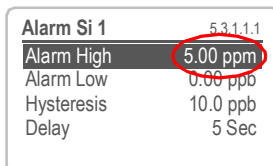

- 1 Select the value you want to change.
- 2 Press [Enter].
- 3 Set required value with [] or [] key.
- 4 Press [Enter] to confirm the new value.
- 5 Press [Exit].
⇒ *Yes is highlighted.*
- 6 Press [Enter] to save the new value.

5.5. Grab Sample Measurement

Status of relays and signal outputs during the procedure:

- ◆ Signal outputs are on hold
- ◆ All limits are switched off

- 1 Navigate to <Operation>/<Grab Sample>.
- 2 Follow the instructions on the screen.

Note:

- *The measured value of the grab sample is not stored.*
- *If an AMI Sample Sequencer is installed, the flow regulating valve [B] on the flow cell block of the constant head must be closed during the grab sample measurement. Otherwise, the grab sample may flow back into the sample feed line.*

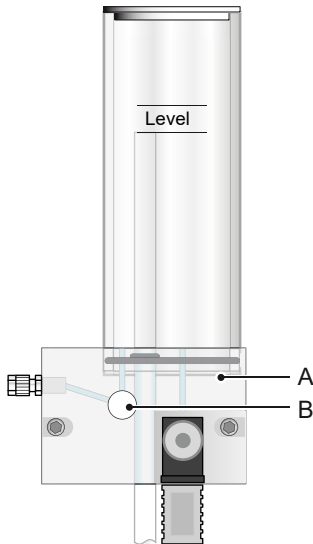

- A** Flow cell block of the constant head
- B** Flow regulating valve

6. Maintenance

6.1. Maintenance Schedule

Weekly	Check sample supply for dirt. Check sample flow.
Monthly	Check reagent level.
Every 6 months	Exchange reagent pump tube.
By occurrence	E020, FOME dirty: Cleaning the Photometer, p. 57 . E022, Reagent empty: Refill or Replace Reagents, p. 50 . E065, Reagents low: Refill or Replace Reagents, p. 50 .

6.2. Stop of Operation for Maintenance

- 1 Put suction lances into a bucket with high purity water.
- 2 Start fill system.
- 3 Wait until the peristaltic pump has stopped.
- 4 Stop sample flow.
- 5 Wait until the constant head is empty.
- 6 Put suction lances into an empty bucket.
- 7 Shut off power of the instrument.



6.3. Refill or Replace Reagents

The liquid level in canister 4 is monitored. The following messages are displayed.

Canister almost empty	Maintenance message E065 "Reagents low" and the remaining reagent volume in % (starting at 17% = 340 ml).
Canister empty	Error message E022 "Reagent empty"

Canister setup

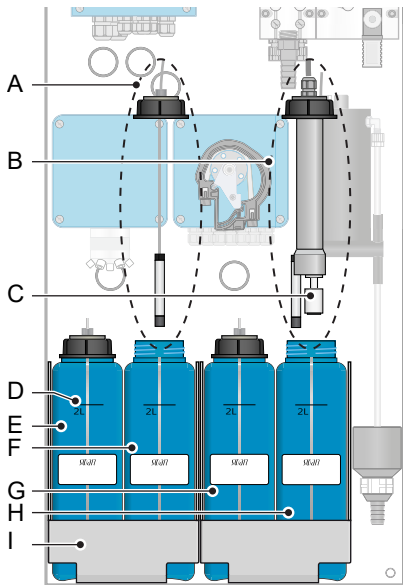

- A** Suction lance without level detector (canisters 1–3)
- B** Suction lance with level detector (canister 4)
- C** Level detector
- D** 2 L mark
- E** Reagent canister 1
- F** Reagent canister 2
- G** Reagent canister 3
- H** Reagent canister 4
- I** Holder

Reagent consumption

The 2 liter reagent canister will last for 1 month of operation with default measurement interval of 10 minutes. The provided reagent set for 3 canister fillings therefore lasts for 3 months of operation.

Measuring interval	Duration per canister	Duration per reagent set
10 minute	~ 1 month	3 months
15 minutes	~ 1.5 months	4.5 months
20 minutes	~ 2 months	6 months
30 minutes	~ 3 months	9 months

Note: Please consider the following two points when preparing new reagents:

- *Reagent 3, Oxalic Acid dissolves very slowly, we therefore recommend to prepare Reagent 3 first.*
- *Reagent 1, add Sodium hydroxide (Reagent 1b) first.*

General procedure

- 1 Rinse all containers well with demineralized water.
- 2 Fill the container to 3/4 of its final level with demineralized water.
- 3 Carefully add the chemicals. See [Reagent 1, p. 52](#), [Reagent 2, p. 52](#), [Reagent 3, p. 52](#), [Reagent 4, p. 52](#)
- 4 Screw the cover onto the container and mix well.
- 5 Fill the container to its final level and mix again.
- 6 Put container into the holder, number 1 to 4 from left to right.
- 7 Insert suction lances into the containers; make sure that the numbers on the suction lances correspond to the numbers on the containers.
- 8 Lock cover.

- Reagent 1** Ammonium molybdate
- ♦ Reagent 1a: Add 56 g of ammonium molybdate tetrahydrate
 - ♦ Reagent 1b: Add 16 g of sodium hydroxide pellets
- Reagent 2** Sulfuric Acid
- ♦ Add 200 ml sulfuric acid 25% to the container.
- Reagent 3** Oxalic Acid
- ♦ Add 40 g oxalic acid dihydrate.
- Reagent 4** Ammonium Ferrous Sulfate
- ♦ Reagent 4a: Add 80 ml sulfuric acid 25%
 - ♦ Reagent 4b: Add 13 g ammonium iron (II) sulfate hexahydrate

All canisters:

Always replace the reagent filters (included with each reagent set) when preparing new reagents.

Insert suction lances into the containers. Make sure that the numbers on the suction lances correspond to the numbers on the containers.

Personal protective equipment:



Reagent 3:

H302: Harmful if swallowed

H312: Harmful in contact with skin

H315: Causes skin irritation.

H318: Causes serious eye damage.

H373: May cause damage to organs through prolonged or repeated exposure.



Reagent 4b:

H315: Causes skin irritation

H319: Causes serious eye irritation

H335: May cause respiratory irritation



Reagent 1b, Reagent 2, Reagent 4a:

H314: Causes severe skin burns and eye damage



6.4. Verification

The “Verification kit for AMI Photometer” is available as an accessory. An optical window with a precisely determined absorbance value is placed into the light beam of the photometer. The actual measured absorbance will be compared to the reference value labeled on each kit.



Relay status during verification:

- Signal outputs are on hold
- All limits are switched off

Set reference value

Prior to performing the verification the reference value, e.g. 0.235, needs to be set in menu <Installation>/<Sensors>/<Ref. Verification> 5.1.2*) Verification reference value.

Verification procedure

Basically follow the dialog in menu <Maintenance>/<Service>/<Verification> 3.2.1*)

Note: Start any time, if a measuring cycle is in progress wait for next prompt.

- 1 Stop sample flow by closing the flow regulating valve. Wait for next prompt: Constant head will be drained and an automatic zero will be defined.
- 2 Open cuvette of the photometer and insert the verification filter. [Enter] to continue.
- 3 Adjust for minimal absorbance (see AMI display).
- 4 Press [Enter] to save the verification measurement. The verification is successful if the difference is within the limits. <Enter> to continue.
- 5 Remove filter, close cuvette and open regulating valve. <Enter> to finish and [Exit] to the main display.

Verification history:

Can be reviewed in menu Verification History <Diagnostics>/<Sensors>/<FOME Sensor>/<Ver. History> 2.2.1.5*

6.5. Calibration

Preparing the standard

Swan offers a 100 ppm stock solution, from which you can produce your own standard. By default, the instrument is programmed for a standard of 100 ppb. Other concentrations can be programmed in menu <Installation>/<Sensors>/<Standard>.

To prepare a 100 ppb standard solution, dilute 1 ml of stock solution with 1 l of demineralized water.

Calibration

- 1 Navigate to <Maintenance>/<Calibration>.
- 2 Follow the instructions on the screen.

Note: If an AMI Sample Sequencer is installed, the flow regulating valve [B] on the flow cell block of the constant head must be closed during the calibration. Otherwise, the standard solution may flow back into the sample feed line.

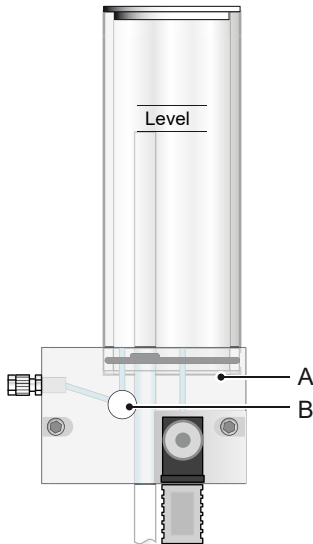

- A Flow cell block of the constant head
- B Flow regulating valve

6.6. Cleaning the Flow Cell



CAUTION

Acrylic glass parts are fragile and scratch-sensitive

Possible damage of acrylic glass parts due to scrubbing materials.

- ◆ Never use organic solvents or scrubbing materials to clean acrylic glass parts.
- ◆ Use soft detergent and rinse well. Eliminate lime deposits with a common household deliming agent in standard concentration.
- ◆ Do not drop the constant head tube

6.6.1 Disassemble the Constant Head

The flow cell can be disassembled easily. Before disassemble the flow cell, switch off the instrument according to instructions in [Stop of Operation for Maintenance, p. 49](#).



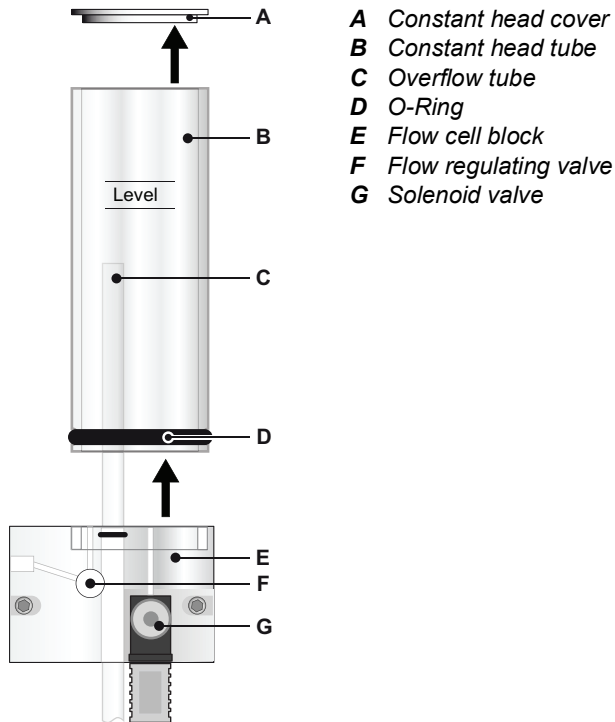

- Cleaning**
- 1 Remove the constant head cover [A].
 - 2 Pull the constant head tube [B] (constant head) out of the flow cell block [E].
 - 3 Clean all acrylic parts with a soft brush (bottle cleaner) and soapy water.
 - 4 Replace all O-rings before reassembling the flow cell.

Note: A film of teflon paste (e.g. Fomblin from Solvay Solexis) on the O-rings improves tightness and life time.

Assemble the Constant Head according to [Install the Constant Head, p. 21](#)

6.7. Cleaning the Photometer

Clean the photometer after indication by alarm (E020, FOME dirty). Before opening the photometer, switch off the instrument according to instructions in [Stop of Operation for Maintenance, p. 49](#)

Material
Procedure

Small brush.

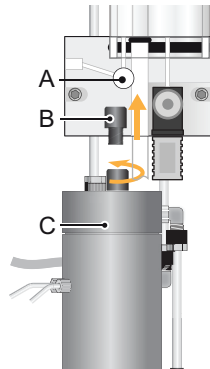

- A** Flow regulating valve
- B** Photometer cover
- C** Photometer
- D** Brush

- 1 Close the flow regulating valve [A].
- 2 Wait until the sample flow through the photometer has stopped
- 3 Unscrew the cover [B] from the photometer [C].

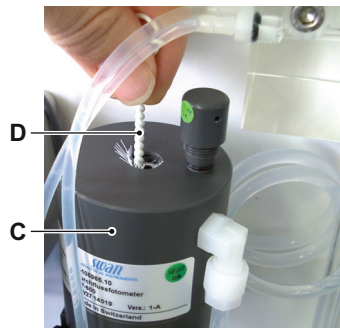

- 4 Clean the photometer with a small brush [D].
- 5 Screw the cover to the photometer.
- 6 Open the flow regulating valve.

6.8. Cleaning the solenoid valve

Disassemble the solenoid valve

The solenoid valve is mounted below the constant head. The solenoid valve should be disassembled if it does not switch anymore or if it is clogged.

- 1 Switch off the instrument according to instructions in [Stop of Operation for Maintenance, p. 49](#).

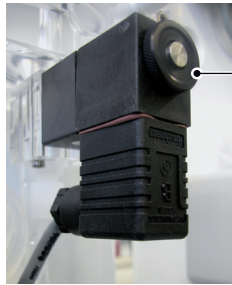

- 2 Loosen the nut (A).

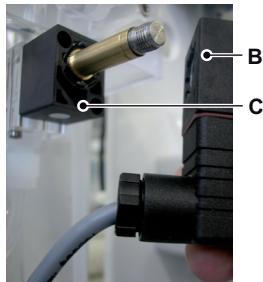

- 3 Remove the solenoid coil (B) from the valve body (C).

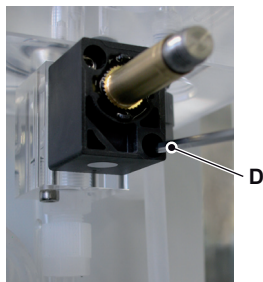

- 4 Loosen the fixing screws of the valve body with a 2.5 mm allen key (D).

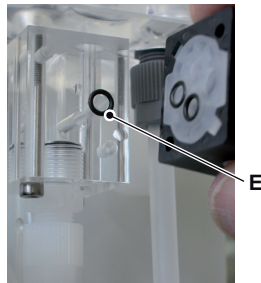

Note: The O-rings inside the valve body may stick on the flow cell and fall down if the valve body is removed.

- 5 Remove the valve body from the flow cell.

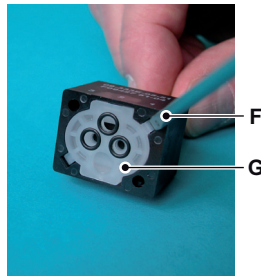

- 6 Remove the white plate (G) with a screw driver size 0 (F).

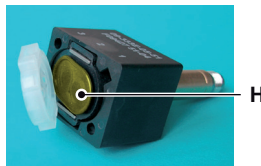

⇒ The membrane (H) is now visible.

- 7 Clean base plate (G) and membrane (H) with clean water.

Assemble Assemble the solenoid valve in reverse order.

6.9. Tube Replacement

6.9.1 Replace the Pump Tubes

The pump tube [D] of the peristaltic pump is exposed to a minimal wear. It is therefore recommended to exchange the pump tube every 6 months.



CAUTION

Pollution of reagents possible

If the occlusion frames are opened during operation, already mixed reagents will flow back into the reagent canisters and pollute the reagents.

- ◆ Never open the occlusion frames if the instrument is in operation.
- ◆ Proceed according to [Stop of Operation for Maintenance, p. 49](#) before opening the occlusion frames.

Overview

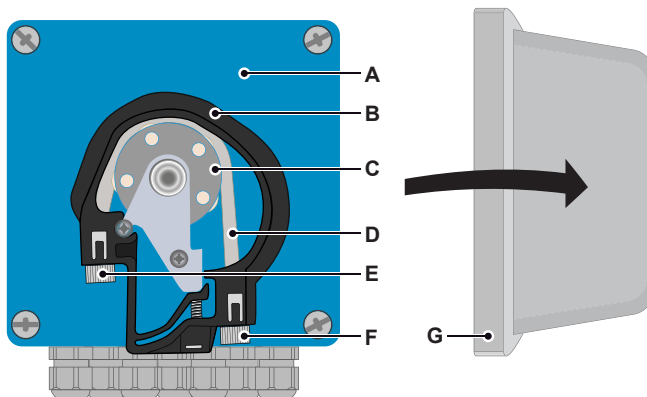

- | | |
|---------------------------------|-------------------------|
| A Pump housing | E Pump inlet |
| B Occlusion frame closed | F Pump outlet |
| C Rotor | G Protection cap |
| D Pump tube | |

**Dismount
pump tubes**

The pump tube can easily be dismantled and mounted. Proceed as follows:

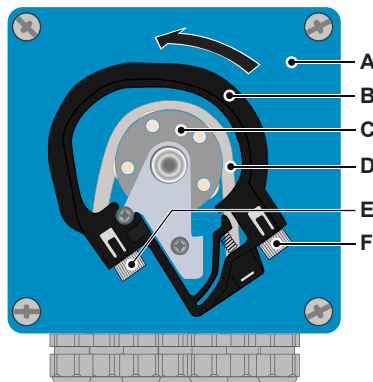

- A** Pump housing
- B** Occlusion frame open
- C** Rotor
- D** Pump tube
- E** Pump inlet
- F** Pump outlet

- 1 Switch off the instrument according to instructions in [Stop of Operation for Maintenance, p. 49](#).
- 2 Remove the protection cap.
- 3 Open the occlusion frame [B] by turning it counter-clockwise.
- 4 Remove the pump tube [D] from the rotor [C] by pulling the complete occlusion frame [B] out of the holder.
- 5 Disconnect the reagent tubes from the old pump tube and connect them to the new pump tube
- 6 Install the new pump tube by pushing the occlusion frame onto the holder.
- 7 Lock the occlusion frame. Check that the occlusion frame and the tube are aligned perpendicular to the axis of the rotor.
- 8 Insert the suction lances into the corresponding canisters.
- 9 Start the <Fill system> function.

6.9.2 Tube Numbering

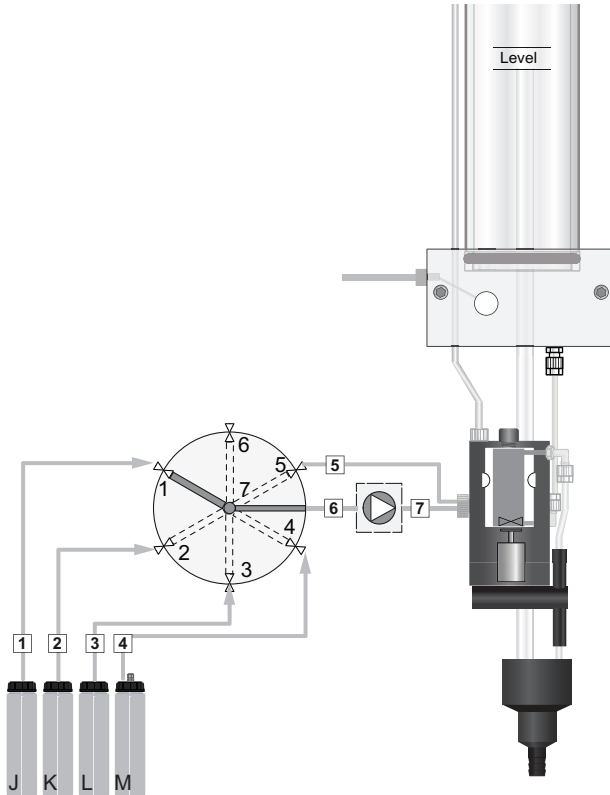

Tube No.	from	to
1	Reagent canister J	6-way valve port 1
2	Reagent canister K	6-way valve port 2
3	Reagent canister L	6-way valve port 3
4	Reagent canister M	6-way valve port 4
5	6-way valve port 5	Photometer
6	6-way valve port 7	Peristaltic pump input
7	Peristaltic pump output	Photometer reagent input

6.10. Fill or Flush Reagent System

Fill or flush the reagent tubing:

- ♦ after refilling the reagent canisters,
- ♦ before a system shut-down to flush the system with demin water until no more reagent is left in the system.

The diagram illustrates the navigation process for filling or flushing the reagent system. It starts with a 'Service' menu (version 3.2.2) where 'Fill System' is selected. Pressing 'Enter' leads to a 'Fill System' progress screen (version 3.2.2.5) with a progress bar and the instruction '<Enter> to stop'. Pressing 'Enter' again leads to a 'Fill System' 'Done' screen (version 3.4.5).

Press 4 x [Exit]

6.11. Longer Stop of Operation

- 1 Proceed according to chapter [Stop of Operation for Maintenance, p. 49](#).
- 2 Empty the measuring cell of the photometer, for example with a pipette and dry it with a soft tissue.
- 3 Relax the occlusion frame of the peristaltic pump. See [Replace the Pump Tubes, p. 60](#).

7. Troubleshooting

This chapter provides some hints to make troubleshooting easier. For any detailed information how to handle or clean parts please see [Maintenance, p. 49](#). For information on how to program the instrument see [Program List and Explanations, p. 79](#).

7.1 Slope Error

Slope error is a calibration error. It occurs, if the correction factor (slope) is > 2.0 or < 0.5 .

Note: *When mixing new reagents or standard solution:*

- *Never use water contaminated with silica.*
- *Do not use any glass containers to mix reagents or standard solution.*

If the calibration factor is too high do the following:

- 1 Check the programmed standard. See chap. 9, [5.1.2, p. 83](#).
- 2 Prepare a new standard solution with demineralized water, use SWAN stock solution only.
- 3 Clean all canisters and suction lances with a mix of demineralized water and one percent hydrochloric acid.
- 4 Prepare new reagents with SWAN original reagents, see [Refill or Replace Reagents, p. 50](#).

If the calibration factor is too low do the following:

- 1 Prepare a new standard solution with demineralized water, use SWAN stock solution only.
- 2 Clean all canisters and suction lances with a mix of demineralized water and one percent hydrochloric acid.
- 3 Check the pump delivery volume.

**Check pump
 delivery
 volume**

A low calibration factor may be caused by leaking tube connections. The delivery volume of the peristaltic pump is approximately 4.2 g/min.

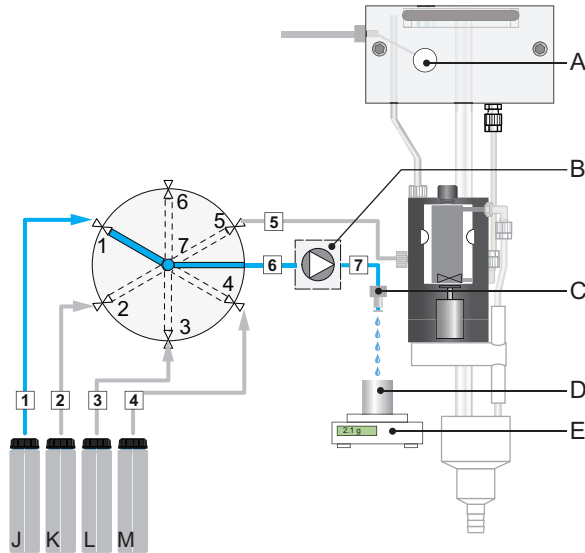

- | | |
|--------------------------------|------------------|
| A Flow regulating valve | D Beaker |
| B Peristaltic pump | E Balance |
| C Tube fitting | |

Check the delivery volume of the peristaltic pump as follows:

- 1 Close the flow regulating valve [A] to stop the sample flow.
- 2 Put a beaker [D] onto a balance [E] and set the balance to zero.
- 3 Unscrew and remove the tube fitting [C] from the photometer to disconnect tube No. 7.
 ⇒ *The sample contained in the photometer will flow out.*
- 4 Put the tube into the beaker.
- 5 Navigate to menu <Maintenance>/<Service>/<Manual Filling> and press [Enter].
- 6 Select <Position> and press [Enter].
- 7 Set the 6-way valve to position 1 with the [▲] or [▼] key.
 ⇒ *The positions 1 to 4 of the 6-way valve are assigned to the 4 canisters.*

- 8 After the 6-way valve position has been set, select <Pump> and press [Enter].
- 9 Set the pump to <on> for a half minute.
⇒ *The reagent is pumped into the beaker.*
- 10 Read the weight on the display of the balance.
⇒ *The weight must be within 2.0 to 2.3 g.*
- 11 Repeat step 6 to 10 and set the 6-way valve to position 2, 3, and 4 to check the tubes of the canisters 2, 3 and 4.

If the reagent volume is below 2 g:

- ◆ check the tube connections for leakage
- ◆ check if a tube is damaged (i.e. kinked)
- ◆ Replace the pump tubes of the peristaltic pump, see [Tube Replacement, p. 60](#)
- ◆ Replace the 6-way valve, see enclosed installation instruction.

7.2. Grab Sample

The grab sample function is normally used to measure an external sample. But it can be used for verification as well. If the grab sample function is used for verification, the deviation to the expected value should be less than 30%. If the deviation is higher or lower than 30%, proceed as described in chapter [Slope Error, p. 64](#).

7.3. Error List

Error

Non-fatal error. Indicates an alarm if a programmed value is exceeded.

Such errors are marked **E0xx** (bold and black).

Fatal error (blinking symbol)

Control of dosing devices is interrupted.

The indicated measured values are possibly incorrect.

Fatal errors are divided in the following two categories:

- ◆ Errors which disappear if correct measuring conditions are recovered (i.e. Sample Flow low).
Such errors are marked **E0xx** (bold and orange)
- ◆ Errors which indicate a hardware failure of the instrument.
Such errors are marked **E0xx** (bold and red)

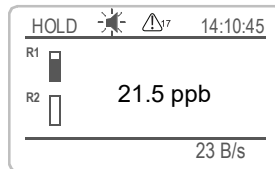

Error or fatal Error

Error not yet acknowledged.
Check **Pending Errors 1.1.5** and take corrective action.

Reagent level low

Indicates the remaining reagent in percent

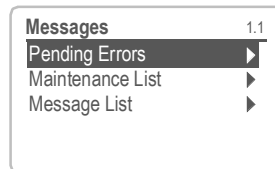

Navigate to menu <Messages>/<Pending Errors>.

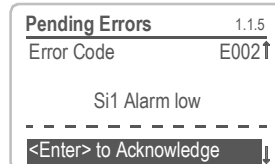

Press [ENTER] to acknowledge the Pending Errors.

⇒ *The error is reset and saved in the message list.*

Error	Description	Corrective action
E001	Si 1 Alarm high	<ul style="list-style-type: none"> – check process – check programmed value 5.3.1.1.1, p. 89
E002	Si 1 Alarm low	<ul style="list-style-type: none"> – check process – check programmed value 5.3.1.1.25, p. 89
E003	Si 2 Alarm high	<ul style="list-style-type: none"> – check process – check programmed value 5.3.1.1.1, p. 89
E004	Si 2 Alarm low	<ul style="list-style-type: none"> – check process – check programmed value 5.3.1.1.25, p. 89
E007	Sample Temp. high	<ul style="list-style-type: none"> – check process – check programmed value
E008	Sample Temp. low	<ul style="list-style-type: none"> – check process – check programmed value
E009	Sample Flow high	<ul style="list-style-type: none"> – check inlet pressure – re-adjust sample flow – check programmed value 5.3.1.3.2, p. 90
E010	Sample Flow low	<ul style="list-style-type: none"> – check inlet pressure – re-adjust sample flow – clean instrument – check programmed value 5.3.1.3.35, p. 90
E012	Temp. disconnected	<ul style="list-style-type: none"> – shut off power – check wiring of photometer, see AMI Silica with “PeriClip” Pump, p. 30
E013	Case Temp. high	<ul style="list-style-type: none"> – check case/environment temperature – check programmed value 5.3.1.4, p. 90
E014	Case Temp. low	<ul style="list-style-type: none"> – check case/environment temperature – check programmed value 5.3.1.51, p. 90
E015	Valve defective	<ul style="list-style-type: none"> – check valve, see Cleaning the solenoid valve, p. 58
E017	Control Timeout	<ul style="list-style-type: none"> – check control device or programming in Installation, Relay contact, Relay 1/2 5.3.2 and 5.3.3, p. 90

Error	Description	Corrective action
E018	Reagent Pump	<ul style="list-style-type: none"> – shut off power – check wiring, see AMI Silica with “PeriClip” Pump, p. 30
E019	FOME not connected	<ul style="list-style-type: none"> – shut off power – check wiring check wiring, see AMI Silica with “PeriClip” Pump, p. 30
E020	FOME dirty	<ul style="list-style-type: none"> – clean photometer, see Cleaning the Photometer, p. 57
E022	Reagent empty	<ul style="list-style-type: none"> – fill reagents, – see Refill or Replace Reagents, p. 50
E023	Sequencer	<ul style="list-style-type: none"> – check Sample Sequencer connection
E024	Input active	<ul style="list-style-type: none"> – See If Fault Yes is programmed in Menu 5.3.4, p. 95
E026	IC LM75	<ul style="list-style-type: none"> – call service
E028	Signal output open	<ul style="list-style-type: none"> – check wiring on signal outputs 1 and 2
E030	I2C Rovalve	<ul style="list-style-type: none"> – call service
E031	Calibration Recout	<ul style="list-style-type: none"> – call service
E032	Wrong Frontend	<ul style="list-style-type: none"> – call service
E033	Sample Flow 1 low (Sample Sequencer)	<ul style="list-style-type: none"> – See manual of Sample Sequencer – If 2nd Sample Stream option is installed, see E010
E034	Sample Flow 2 low (Sample Sequencer)	<ul style="list-style-type: none"> – See manual of Sample Sequencer – If 2nd Sample Stream option is installed, see E010
E035	Sample Flow 3 low (Sample Sequencer)	<ul style="list-style-type: none"> – See manual of Sample Sequencer
E036	Sample Flow 4 low (Sample Sequencer)	<ul style="list-style-type: none"> – See manual of Sample Sequencer
E037	Sample Flow 5 low (Sample Sequencer)	<ul style="list-style-type: none"> – See manual of Sample Sequencer



Error	Description	Corrective action
E038	Sample Flow 6 low (Sample Sequencer)	– See manual of Sample Sequencer
E049	Power-on	– none, normal status
E050	Power-down	– none, normal status
E065	Reagent low	Observe the decreasing number on the screen, indicating for how many hours the reagent lasts. Refill reagents on time. See Refill or Replace Reagents, p. 50

7.4. Electrical Connections Inside the Peristaltic Pump

Note: Check the type label of the peristaltic pump to see which version (“Pump PeriClip V2 for AMI” or “Pump PeriClip”) is installed. The terminal assignment is different depending on the version.

General For some electrical connections (e.g. when replacing suction lancets), it is necessary to open the housing of the peristaltic pump. To do this, proceed as follows:

- 1 Switch off the analyzer according to [Stop of Operation for Maintenance, p. 49](#).
- 2 Remove the protection cap and all pump tubes as described in [Dismount pump tubes, p. 61](#).
- 3 Unscrew the 4 screws of the peristaltic pump housing and remove the cover.
- 4 Disconnect the motor connector [A].

“PerClip V2 for AMI” pump

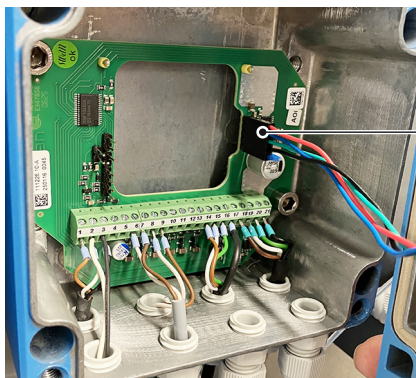

A Motor connector

- 5 Feed the cable into the housing through one of the M12 cable glands.
- 6 Connect the cable to the terminal block of the peristaltic pump according to [AMI Silica with “PeriClip V2 for AMI” Pump, p. 29](#).
- 7 Reassemble in reverse order.

- “PeriClip”
pump** **4** Disconnect the motor connector [A].



A Motor connector

- 5** Feed the cable into the housing through one of the PG7 cable glands.
- 6** Connect the cable to the terminal block of the peristaltic pump according to [AMI Silica with “PeriClip” Pump, p. 30](#).
- 7** Reassemble in reverse order.

7.5 Replacing Fuses



WARNING

External voltage

Externally supplied devices connected to relay 1 or 2 or to the alarm relay can cause electrical shocks.

- ◆ Make sure that the devices connected to the following contacts are disconnected from the power before resuming installation.
 - relay 1
 - relay 2
 - alarm relay

When a fuse has blown, find out the cause and fix it before replacing it with a new one.

Use tweezers or needle-nosed pliers to remove the defective fuse. Use original fuses provided by SWAN only.

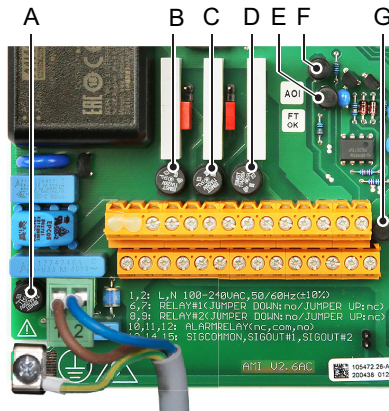

- A** AC variant: 1.6 AT/250 V Instrument power supply
DC variant: 3.15 AT/250 V Instrument power supply
- B** 1.0 AT/250V Relay 1
- C** 1.0 AT/250V Relay 2
- D** 1.0 AT/250V Alarm relay
- E** 1.0 AF/125V Signal output 2
- F** 1.0 AF/125V Signal output 1
- G** 1.0 AF/125V Signal output 3

8. Program Overview

For explanations about each parameter of the menus see [Program List and Explanations, p. 79](#).

- ◆ Menu 1 **Messages** informs about pending errors and maintenance tasks and shows the error history. Password protection possible. No settings can be modified.
- ◆ Menu 2 **Diagnostics** is always accessible for everybody. No password protection. No settings can be modified.
- ◆ Menu 3 **Maintenance** is for service: Calibration, simulation of outputs and set time/date. Please protect with password.
- ◆ Menu 4 **Operation** is for the user, allowing to set limits, alarm values, etc. The presetting is done in the menu Installation (only for the System engineer). Please protect with password.
- ◆ Menu 5 **Installation**: Defining assignment of all inputs and outputs, measuring parameters, interface, passwords, etc. Menu for the system engineer. Password strongly recommended.

8.1. Messages (Main Menu 1)

Pending Errors 1.1*	<i>Pending Errors</i>	1.1.5*
Maintenance List 1.2*	<i>Maintenance List</i>	1.2.5*
Message List 1.3*	<i>Number</i> <i>Date, Time</i>	1.3.1*

* Menu numbers

8.2. Diagnostics (Main Menu 2)

Identification	Designation	AMI Silica		* Menu numbers
2.1*	Version	V6.22-01/22		
	Peripherals	<i>PeriClip 1.06</i>	2.1.3.1*	
	2.1.3	RoValve 1.60		
	Factory Test	<i>Instrument</i>	2.1.4.1*	
	2.1.4*	<i>Motherboard</i>		
	Operating Time	<i>Years / Days / Hours / Minutes / Seconds</i>		2.1.5.1*
	2.1.5*			
Sensors	FOME Sensor	<i>Current Value ppb</i>		
2.2*	2.2.1*	<i>(Raw value) V</i>		
		<i>Absorbance</i>		
		Cal. History	<i>Number</i>	2.2.1.4.1*
		2.2.1.4*	<i>Date, Time</i>	
			<i>Slope</i>	
		Ver. History	<i>Number</i>	2.2.1.5.1*
		2.2.1.5*	<i>Date, Time</i>	
			<i>Absorbance</i>	
			<i>Reference value</i>	
	Miscellaneous	<i>Case Temp.</i>	2.2.2.1*	
	2.2.2*	<i>State Machine</i>		
Sample	<i>Sample ID</i>	2.3.1*		
2.3*	<i>Temperature</i>			
	<i>Sample Flow</i>			
I/O State	<i>Alarm Relay</i>	2.4.1*		
2.4*	<i>Relay 1/2</i>	2.4.2*		
	<i>Input</i>			
	<i>Signal Output 1/2</i>			
Interface	<i>Protocol</i>	2.5.1*		(only with RS485 interface)
2.5*	<i>Baud rate</i>			

8.3. Maintenance (Main Menu 3)

Calibration	<i>Calibration</i>	<i>Progress</i>		* Menu numbers
3.1*	3.1.5*			
Service	Verification	<i>(Progress)</i>	3.2.1.1*	
3.2*	3.2.1*			
	Fill System	<i>(Progress)</i>	3.2.2.5*	
	3.2.2*			
	Manual Filling	<i>Position</i>	3.2.3.1*	
	3.2.3	<i>Pump</i>	3.2.3.2*	
Simulation	<i>Alarm Relay</i>	3.3.1*		
3.3*	<i>Relay 1</i>	3.3.2*		
	<i>Relay 2</i>	3.3.3*		
	<i>Signal Output 1</i>	3.3.4*		
	<i>Signal Output 2</i>	3.3.5*		
	<i>Magnetic valve 1</i>	3.3.6*		
	<i>Magnetic valve 2</i>	3.3.7*		
	<i>Stirrer</i>	3.3.8*		
Set Time	<i>(Date), (Time)</i>			
3.4*				

8.4. Operation (Main Menu 4)

Grab Sample

4.1*

Sensors

Filter Time Const. 4.2.1*

4.2*

Hold after Cal. 4.2.2*

Relay Contacts

Alarm Relay **Alarm Si 1 (Si 2)** *Alarm High* 4.3.1.1.1*

4.3*

4.3.1*

4.3.1.1*

Alarm Low 4.3.1.1.25*

Hysteresis 4.3.1.1.35*

Delay 4.3.1.1.45*

Relay 1/2 *Setpoint* 4.3.x.100*

4.3.2* - 4.3.3* *Hysteresis* 4.3.x.200*

Delay 4.3.x.30*

	Input	<i>Active</i>	4.3.4.1*	* Menu numbers
	4.3.4*	<i>Signal Outputs</i>	4.3.4.2*	
		<i>Output / Control</i>	4.3.4.3*	
		<i>Fault</i>	4.3.4.4*	
		<i>Delay</i>	4.3.4.5*	
Logger	<i>Log Interval</i>	4.4.1*		
4.4*	<i>Clear Logger</i>	4.4.2*		

8.5. Installation (Main Menu 5)

Sensors	<i>Ref. Veification</i>	5.1.1*		
5.1*	<i>Standard</i>	5.1.2*		
	<i>Blank</i>	5.1.3*		
	<i>Meas. interval</i>	5.1.4*		
	<i>Channels</i>	5.1.5*		
	<i>Channel Selection</i>	5.1.6*		
Signal Outputs	Signal Output 1/2	<i>Parameter</i>	5.2.1.1 - 5.2.2.1*	
5.2*	5.2.1* - 5.2.2*	<i>Current Loop</i>	5.2.1.2 - 5.2.2.2*	
		<i>Function</i>	5.2.1.3 - 5.2.2.3*	
		Scaling	<i>Range Low</i>	5.2.x.40.12/10*
		5.2.x.40	<i>Range High</i>	5.2.x.40.22/20*
	Signal Sequencer	<i>Parameter</i>	5.2.4.1*	
	5.2.4*	<i>Current Loop</i>	5.2.4.2*	
		<i>Function</i>	5.2.4.3*	
		Scaling	<i>Range Low</i>	5.2.4.40.10*
		5.2.4.40*	<i>Range High</i>	5.2.4.40.20*
Relay Contacts	Alarm Relay	Alarm Si 1(Si 2)	<i>Alarm High</i>	5.3.1.1.1*
5.3*	5.3.1*	5.3.1.1*	<i>Alarm Low</i>	5.3.1.1.25
			<i>Hysteresis</i>	5.3.1.1.35
			<i>Delay</i>	5.3.1.1.45
		Sample Temp.	<i>Alarm High</i>	5.3.1.2.1*
		5.3.1.2	<i>Alarm Low</i>	5.3.1.2.25*
		Sample Flow	<i>Flow Alarm</i>	5.3.1.3.1*
		5.3.1.3*	<i>Alarm High</i>	5.3.1.3.2*
			<i>Alarm Low</i>	5.3.1.3.35*
		<i>Case Temp. high</i>	5.3.1.4*	
		<i>Case Temp. low</i>	5.3.1.51*	



	Relay 1/2	<i>Function</i>	5.3.2.1 - 5.3.3.1*	* Menu numbers
	5.3.2* - 5.3.3*	<i>Parameter</i>	5.3.2.20 - 5.3.3.20*	
		<i>Setpoint</i>	5.3.2.302-5.3.3.302*	
		<i>Hysteresis</i>	5.3.2.402-5.3.3.402*	
		<i>Delay</i>	5.3.2.50 - 5.3.3.50*	
	Input	<i>Active</i>	5.3.4.1*	
	5.3.4*	<i>Signal Outputs</i>	5.3.4.2*	
		<i>Output/Control</i>	5.3.4.3*	
		<i>Fault</i>	5.3.4.4*	
		<i>Delay</i>	5.3.4.5*	
Miscellaneous	<i>Language</i>	5.4.1*		
5.4*	<i>Set defaults</i>	5.4.2*		
	<i>Load Firmware</i>	5.4.3*		
	Password	<i>Messages</i>	5.4.4.1*	
	5.4.4*	<i>Maintenance</i>	5.4.4.2*	
		<i>Operation</i>	5.4.4.3*	
		<i>Installation</i>	5.4.4.4*	
	<i>Sample ID</i>	5.4.5*		
	<i>Line Break Detection</i>	5.4.6*		
Interface	<i>Protocol</i>	5.5.1*		(only with RS485 interface)
5.5*	<i>Device Address</i>	5.5.21*		
	<i>Baud Rate</i>	5.5.31*		
	<i>Parity</i>	5.5.41*		

9. Program List and Explanations

1 Messages

1.1 Pending Errors

- 1.1.5 Provides the list of active errors with their status (active, acknowledged). If an active error is acknowledged, the alarm relay is active again. Cleared errors are moved to the Message list.

1.2 Maintenance List

- 1.2.5 Demands necessary maintenance, e.g. preparing new reagents.

1.3 Message List

- 1.3.1 Shows the error history: Error code, date / time of issue and status (active, acknowledged, cleared). 64 errors are memorized. Then the oldest error is cleared to save the newest error (circular buffer).

2 Diagnostics

In diagnostics mode, the values can only be viewed, not modified.

2.1 Identification

Designation: Designation of the instrument.

Version: Firmware of the instrument (e.g. V6.22-01/22)

2.1.3 Peripherals:

- 2.1.3.1 *PeriClip*: Firmware of peristaltic pump (e.g. 1.06)
RoValve: Firmware of rotary valve (6-way valve) (e.g. 1.60)

2.1.4 Factory Test: Test date of instrument and motherboard.

2.1.5 Operating Time: Years / days / hours / minutes / seconds.

2.2 Sensors

2.2.1 FOME Sensor:

Current value: Shows the actual photometer signal in ppb.

Raw value: Shows the actual photometer signal in V.

Absorbance: Process value, depends on sample.

- 2.2.1.4 **Cal. History:** Review diagnostic values of the last calibrations. Factor (slope).

Max. 64 data records are memorized. One calibration step corresponds to one data record:

Slope photometer: 0.5–2.0

- 2.2.1.5 **Ver. History:** Review verifications values of the last verifications:

Absorbance: Measured absorbance of the reference kit.

Reference value: True value of the reference kit according to label.

2.2.2 Miscellaneous:

- 2.2.2.1 *Case Temp*: Shows the actual temperature in [°C] inside the transmitter.
- State Machine*: Number 1–7 are assigned to the initial start up procedure.
Number 8–23 are assigned to the measuring cycle.

Machine state	6-way valve position	peristaltic pump
9	5	on
10	5	on
11	5	off
12	1	on
13	2	on
14	5	on
15	5	off
16	3	on
17	5	on
18	5	off
19	4	on
20	5	on
21	5	off
22		
23		

Number 24 is assigned to the manual filling function.
Number 25–31 are assigned to the calibration procedure.
Number 32–35 are assigned to the verifying procedure.

2.3 Sample

- 2.3.1 *Sample ID*: Review the programmed code. The code is defined by the user to identify the sample point in the plant.
- Temperature*: Shows the Actual temperature in °C.
- Sample flow*: Shows the actual sample flow [B/s] (bubbles per second). Sample flow must be above 5 B/s.

2.4 I/O State

Shows actual status of all in- and outputs.

2.4.1 and 2.4.2

<i>Alarm Relay:</i>	Active or inactive
<i>Relay 1 and 2:</i>	Active or inactive
<i>Input:</i>	Open or closed
<i>Signal Output 1 and 2:</i>	Actual current in mA
<i>Signal Output 3:</i>	Actual current in mA (if option is installed)

2.5 Interface

Only available if optional interface is installed.
Review programmed communication settings.

3 Maintenance

3.1 Calibration

- 3.1.5 Performs a calibration using the standard solution. Follow the instruction on the screen. See [Calibration, p. 54](#)

3.2 Service

- 3.2.1 **Verification:** Performs a verification using the verification kit. Follow the instruction on the screen. See [Verification, p. 53](#).
- 3.2.2 **Fill System:** Activates the reagent pump and fills all tubes from the canister to the 6-way valve.
- 3.2.3 **Manual Filling:** In the menu <Manual filling> the position of the 6-way valve can be set manually and the peristaltic pump can be switched on and off.
 - 3.2.3.1 *Position:* Set the position of the 6-way valve.
 - Pos. 1 Reagent 1
 - Pos. 2 Reagent 2
 - Pos. 3 Reagent 3
 - Pos. 4 Reagent 4
 - Pos. 5 Loop
 - Pos. 6 –
 - 3.2.3.2 *Pump:* Switch the peristaltic pump on or off.

3.3 Simulation

Select the alarm relay, relay 1 and 2, signal output 1 and 2, input, magnetic valve 1 and 2 or stirrer with the up/down keys. Then press <Enter> to change the setting or value. After confirming the setting with the Enter key, the value is simulated by the relay/signal output.

<i>Alarm Relay:</i>	Active or inactive
<i>Relay 1 and 2:</i>	Active or inactive
<i>Input:</i>	Open or closed
<i>Signal Output 1 and 2:</i>	Actual current in mA
<i>Signal Output 3:</i>	Actual current in mA (if option is installed)
<i>Magnetic valve 1</i>	Active or inactive
<i>Magnetic valve 2</i>	Active or inactive
<i>Stirrer</i>	Active or inactive

At the absence of any key activities, the instrument will switch back to normal mode after 20 min. If you quit the menu, all simulated values will be reset.

3.4 Set Time

Adjust date and time.

4 Operation

4.1 Grab Sample

- 4.1.5 Starts a grab sample measurement. Follow the instruction on the screen. See [Grab Sample Measurement, p. 48](#)

4.2 Sensors

- 4.2.1 *Filter Time Constant:* Used to damp noisy signals. The higher the filter time constant, the slower the system reacts to changes of the measured value.
Range: 5–300 Sec
- 4.2.2 *Hold after Cal:* Delay permitting the instrument to stabilize again after calibration. During calibration, verification or grab sample plus hold-time, the signal outputs are frozen (held on last valid value), alarm values, limits are not active.
Range: 0–6'000 Sec

4.3 Relay Contacts

See [5.3 Relay Contacts, p. 89](#)

4.4 Logger

The instrument is equipped with an internal logger. The logger data can be copied to a PC with an USB stick if option USB interface is installed.

The logger can save approx. 1500 data records. Records consists of: Date, time, alarms, measured value, temperature, flow.

Range: 1 second to 1 hour

- 4.4.1 *Log Interval:* Select a convenient log interval. Consult the table below to estimate the max logging time. When the logging buffer is full, the oldest data record is erased to make room for the newest one (circular buffer).

Event driven or interval (see table below)

Interval	1 s	5 s	1 min	5 min	10 min	30 min	1 h	Event Driven
Time	25 min	2 h	25 h	5 d	10 d	31 d	62 d	

- 4.4.2 *Clear Logger:* If confirmed with <yes>, the complete logger data is deleted. A new data series is started.

5 Installation

5.1 Sensors

- 5.1.1 *Ref. Verification:* Set absorbance value of verification kit according to label.
 Range: 0.150–0.600
- 5.1.2 *Standard:* Set the value in ppb of the standard you use for calibration.
 Range: 50 ppb–5 ppm
- 5.1.3 *Blank:* If the reagents contain a known amount of Silica, “Blank” can be used to shift the zero point. The entered Blank value then is subtracted from the measuring value.
 Range: 0.0 ppb–10.0 ppb
- 5.1.4 *Meas. Interval:* The measuring interval can be set to 10, 15, 20 or 30 minutes.
- 5.1.5 *Channels:*
 If the 2nd sample stream option is installed, you can choose 1 or 2 channels.
 If an AMI Sample Sequencer is connected to the AMI Silica, you can choose 1 to 6 channels.

- 5.1.6 **Channel Selection:** The following 3 operating modes can be set:
- ◆ Internal
 - ◆ Fieldbus
 - ◆ External

Mode Internal

In the mode internal, the AMI Silica works as a master.

2nd Sample Stream Option

The AMI Silica switches automatically between channel 1 and 2.

Sample Sequencer

The AMI Silica sequentially measures each single sample stream of the Sample Sequencer.

Via an external PLC it can be defined which sample streams should not be measured. In the example below, only the samples streams 2, 4 and 6 are measured, whereas the samples streams 1, 3 and 5 are switched off. Sample streams which are switched off are marked with an “x” behind the measuring value on the AMI Silica display.

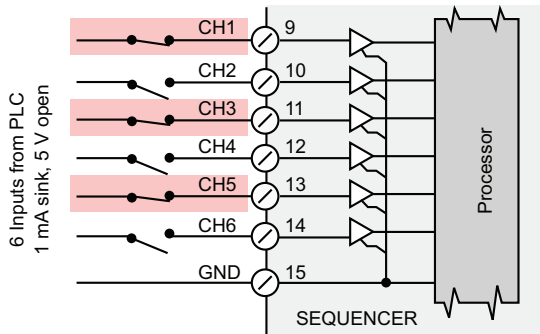

Mode Fieldbus

The AMI Silica is controlled via fieldbus.

Mode External

In the mode external, the AMI Silica works as a slave.

2nd Sample Stream Option

The 2nd Sample Stream option is switched between sample stream 1 and 2 via input, see Input [5.3.4, p. 95](#).

Sample Sequencer

The AMI Silica is controlled by the Sample Sequencer. The Sample Sequencer in turn is controlled via an external PLC. Each sample stream to be measured has to be activated by closing the respective contact.

Example:

If sample stream 1 of the Sample Sequencer is active, the AMI Silica measures the sample stream 1 until the Sample Sequencer changes to the next programmed channel. In the example below, the sample stream 3 (CH3) highlighted in green will be measured as soon as the AMI analyzer has finished the previous measurement. The current measurement is completed before the channel is switched.

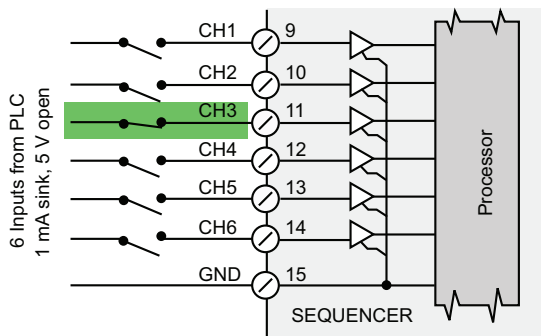

5.2 Signal Outputs

5.2.1 and 5.2.2 Signal Output 1 and 2: Assign process value, the current loop range and a function to each signal output.

Note: The navigation in the menu <Signal Output 1> and <Signal Output 2> is equal. For reason of simplicity only the menu numbers of Signal Output 1 are used in the following.

- 5.2.1.1 **Parameter:** Assign one of the process values to the signal output.
 Available values:
 - ◆ Temperature
 - ◆ Sample Flow
 - ◆ Si 1
- 5.2.1.2 **Current Loop:** Select the current range of the signal output. Make sure the connected device works with the same current range.
 Available ranges: 0–20 mA or 4–20 mA
- 5.2.1.3 **Function:** Define if the signal output is used to transmit a process value or to drive a control unit. Available functions are:
 - ◆ Linear, bilinear or logarithmic for process values.
 See [As process values, p. 86](#)
 - ◆ Control upwards or control downwards for controllers.
 See [As control output, p. 87](#)

As process values The process value can be represented in 3 ways: linear, bilinear or logarithmic. See graphs below.

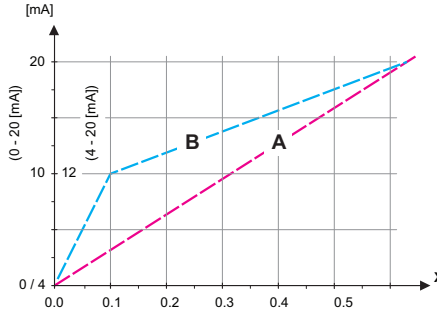

A linear **X** Measured value
B bilinear

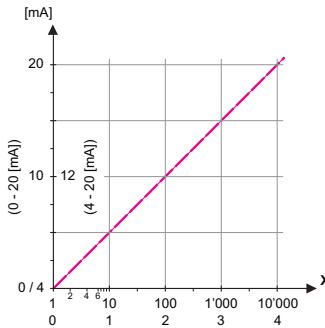

X Measured value (logarithmic)

5.2.1.40 Scaling: Enter beginning and end point (Range low & high) of the linear or logarithmic scale. In addition, the midpoint for the bilinear scale.

Parameter Temperature

- 5.2.1.40.10 Range low: -30 °C to + 120 °C
- 5.2.1.40.20 Range high: -30 °C to + 120 °C

Parameter Sample Flow

- 5.2.1.40.11 Range low: 0–600 B/s
- 5.2.1.40.21 Range high: 0–600 B/s

Parameter Si 1

- 5.2.1.40.12 Range low: 0 ppb–5 ppm

5.2.1.40.22 Range high: 0 ppb–5 ppm

As control output

Signal outputs can be used for driving control units. We distinguish different kinds of controls:

- ◆ *P-controller*: The controller action is proportional to the deviation from the setpoint. The controller is characterized by the P-Band. In the steady-state, the setpoint will never be reached. The deviation is called steady-state error. Parameters: setpoint, P-Band
- ◆ *PI-controller*: The combination of a P-controller with an I-controller will minimize the steady-state error. If the reset time is set to zero, the I-controller is switched off. Parameters: setpoint, P-Band, reset time.
- ◆ *PD-controller*: The combination of a P-controller with a D-controller will minimize the response time to a fast change of the process value. If the derivative time is set to zero, the D-controller is switched off. Parameters: setpoint, P-Band, derivative time.
- ◆ *PID-controller*: The combination of a P-, an I - and a D-controller allows a proper control of the process. Parameters: setpoint, P-Band, reset time, derivative time.

Ziegler-Nichols method for the optimization of a PID controller:

Parameters: Setpoint, P-Band, reset time, derivative time.

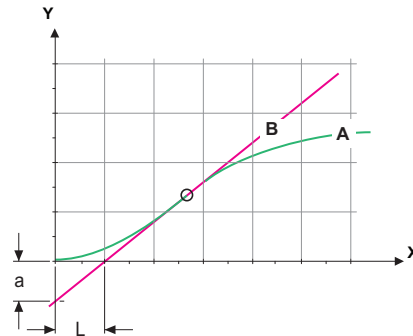

- A** Response to maximum control output $X_p = 1.2/a$
- B** Tangent on the inflection point $T_n = 2L$
- X** Time $T_v = L/2$

The point of intersection of the tangent with the respective axis will result in the parameters a and L.

Consult the manual of the control unit for connecting and programming details. Choose control upwards or downwards.

Control upwards/downwards

Setpoint: User-defined process value (Measured value or flow)

P-Band: Range below (upwards control) or above (downwards control) the set-point, within the dosing intensity is reduced from 100% to 0% to reach the set-point without overshooting.

- 5.2.1.43** Control Parameters: Temperature
- 5.2.1.43.10 *Setpoint:* -30 °C to +120 °C
- 5.2.1.43.20 *P-Band:* 0 °C to +100 °C
- 5.2.1.43** Control Parameters: Sample Flow
- 5.2.1.43.11 *Setpoint:* 0–600 B/s
- 5.2.1.43.21 *P-Band:* 0–200 B/s
- 5.2.1.43** Control Parameters: Si 1
- 5.2.1.43.12 *Setpoint:* 0 ppb–5 ppm
- 5.2.1.43.22 *P-Band:* 0 ppb–5 ppm
- 5.2.1.43.3 *Reset time:* The reset time is the time till the step response of a single I-controller will reach the same value as it will be suddenly reached by a P-controller.
Range: 0–9'000 sec
- 5.2.1.43.4 *Derivative time:* The derivative time is the time till the ramp response of a single P-controller will reach the same value as it will be suddenly reached by a D-controller.
Range: 0–9'000 sec
- 5.2.1.43.5 *Control timeout:* If a controller action (dosing intensity) is constantly over 90% during a defined period of time and the process value does not come closer to the setpoint, the dosing process will be stopped for safety reasons.
Range: 0–720 min
- 5.2.4** **Signal Sequencer:** Only visible if a Sample Sequencer is connected. Assign process value, the current loop range and a function to the signal output.
- 5.2.4.1 *Parameter:* Only the parameter “Si Sequencer” is available.
- 5.2.4.2 *Current Loop:* Select the current range of the signal output. Make sure the connected device works with the same current range. Available ranges: 0–20 mA or 4–20 mA
- 5.2.4.3 *Scaling:* Define the scaling of the signal output used to transmit a process value. Available functions are:
- ♦ Linear, bilinear or logarithmic for process values.
See [As process values, p. 86](#)

5.3 Relay Contacts

5.3.1 Alarm Relay: The alarm relay is used as cumulative error indicator. Under normal operating conditions the contact is active.

The contact is inactive at:

- ◆ Power loss
- ◆ Detection of system faults like defective sensors or electronic parts
- ◆ High case temperature
- ◆ Lack of reagents
- ◆ Process values out of programmed ranges.

Program alarm levels, hysteresis values and delay times for the following parameters:

- ◆ Alarm Si 1
- ◆ Sample Temp.
- ◆ Sample Flow
- ◆ Case Temp. high
- ◆ Case Temp. low

5.3.1.1 Alarm Si 1

5.3.1.1.1 *Alarm High:* If the measured value rises above the alarm high value, the alarm relay is activated and E001 (E003), is displayed in the message list.

Range: 0.00 ppb–5.00 ppm

5.3.1.1.25 *Alarm Low:* If the measured value falls below the alarm low value, the alarm relay is activated and E002 (E004) is displayed in the message list.

Range: 0.00 ppb–5.00 ppm

5.3.1.1.35 *Hysteresis:* Within the hyst. range, the relay does not switch. This prevents damage of relays contacts when the measured value fluctuates around the alarm value.

Range: 0.00 ppb–5.00 ppm

5.3.1.1.45 *Delay:* Duration, the activation of the alarm relay is retarded after the measuring value has risen above/fallen below the programmed alarm.
Range: 0–28'800 Sec

5.3.1.2 Sample Temp.: Define at which sample temperature an alarm should be issued.

5.3.1.2.1 *Alarm High:* If the measured value rises above the alarm high value, the alarm relay is activated.
Range: 30–70 °C

5.3.1.2.25 *Alarm Low:* If the measured value rises above the alarm high value, the alarm relay is activated.
Range: 0–20 °C

5.3.1.3 Sample Flow: Define at which sample flow a flow alarm should be issued.

5.3.1.3.1 *Flow Alarm:* Program if the alarm relay should be activated if there is a flow alarm. Choose between yes or no. The flow alarm will always be indicated in the display, pending error list, saved in the message list and the logger.
Available values: Yes or no

Note: *Sufficient flow is essential for a correct measurement. We recommend to program yes.*

5.3.1.3.2 *Alarm High:* If the measuring values rises above the programmed value E009 will be issued.
Range: 100–600 B/s

5.3.1.3.35 *Alarm Low:* If the measuring values falls below the programmed value E010 will be issued.
Range: 5–80 B/s

5.3.1.4 *Case Temp. high:* Set the alarm high value for temperature of electronics housing. If the value rises above the programmed value E013 is issued.
Range: 30–75 °C

5.3.1.51 *Case Temp. low:* Set the alarm low value for temperature of electronics housing. If the value falls below the programmed value E014 is issued.
Range: -10–20 °C

5.3.2 and 5.3.3 Relay 1 and 2: The contacts can be set as normally open or normally closed with a jumper. See [Relay 1 and 2, p. 33](#). The function of relay contacts 1 or 2 are defined by the user.

Note: *The navigation in the menu <Relay 1> and <Relay 2> is equal. For reason of simplicity only the menu numbers of Relay 1 are used in the following.*

- 1 First select the functions as:
- Limit upper/lower,

- Control upwards/downwards,
- Timer
- Fieldbus
- End of Batch (relay 2 only)
- Channel Selection (relay 2 only)

2 Then enter the necessary data depending on the selected function.

5.3.2.1 Function = Limit upper/lower:

When the relays are used as upper or lower limit switches, program the following:

5.3.2.20 *Parameter:* select a process value

5.3.2.300 *Setpoint:* If the measured value rises above respectively falls below the set-point, the relay is activated.

Parameter	Range
Temperature	-30 °C to + 120 °C
Sample Flow	0–600 B/s
Si 1	0 ppb –5 ppm

5.3.2.401 *Hysteresis:* within the hysteresis range, the relay does not switch. This prevents damage of relay contacts when the measured value fluctuates around the alarm value.

Parameter	Range
Temperature	0 °C –100 °C
Sample Flow	0–200 B/s
Si 1	0 ppb –5 ppm

5.3.3.50 *Delay:* Duration, the activation of the alarm relay is retarded after the measuring value has risen above/fallen below the programmed alarm.

Range. 0–600 Sec

5.3.2.1 Function = Control upwards/downwards:

The relays may be used to drive control units such as solenoid valves, membrane dosing pumps or motor valves. When driving a motor valve both relays are needed, relay 1 to open and relay 2 to close the valve.

5.3.2.22 *Parameter*: Choose on of the following process values.

- ◆ Temperature
- ◆ Sample Flow
- ◆ Si 1

5.3.2.32 Settings: Choose the respective actuator:

- ◆ Time proportional
- ◆ Frequency
- ◆ Motor valve

5.3.2.32.1 Actuator = Time proportional

Examples of metering devices that are driven time proportional are solenoid valves, peristaltic pumps. Dosing is controlled by the operating time.

5.3.2.32.20 *Cycle time*: duration of one control cycle (on/off change).
Range: 0–600 Sec.

5.3.2.32.30 *Response time*: Minimal time the metering device needs to react.
Range: 0–240 Sec.

5.3.2.32.4 Control Parameters

Range for each Parameter same as [5.2.1.43, p. 88](#)

5.3.2.32.1 Actuator = Frequency

Examples of metering devices that are pulse frequency driven are the classic membrane pumps with a potential free triggering input. Dosing is controlled by the repetition speed of dosing shots.

5.3.2.32.21 *Pulse frequency*: Max. pulses per minute the device is able to respond to. Range: 20–300/min.

5.3.2.32.31 Control Parameters

Range for each Parameter same as [5.2.1.43, p. 88](#)

5.3.2.32.1 Actuator = Motor valve

Dosing is controlled by the position of a motor driven mixing valve.

5.3.2.32.22 *Run time*: Time needed to open a completely closed valve
Range: 5–300 Sec.

5.3.2.32.32 *Neutral zone*: Minimal response time in % of the runtime. If the requested dosing output is smaller than the response time, no change will take place.
Range: 1–20 %

- 5.3.2.32.4** Control Parameters
Range for each Parameter same as [5.2.1.43, p. 88](#)
- 5.3.2.1 Function = Timer:
- The relay will be activated repetitively depending on the programmed time scheme.
- 5.3.2.24 *Mode*: Operating mode (interval, daily, weekly)
- 5.3.2.24 *Interval*
- 5.3.2.340 *Interval*: The interval can be programmed within a range of 1–1'440 min.
- 5.3.2.44 *Run Time*: Enter the time the relay stays active.
Range: 5–32'400 Sec.
- 5.3.2.54 *Delay*: during run time plus the delay time the signal and control outputs are held in the operating mode programmed below.
Range: 0–6'000 Sec.
- 5.3.2.6 *Signal Outputs*: Select operating mode of the signal output:
- Cont.:* Signal outputs continue to issue the measured value.
- Hold:* Signal outputs hold the last valid measured value. Measurement is interrupted. Errors, except fatal errors, are not issued.
- Off:* Signal outputs are switched off (set to 0 or 4 mA). Errors, except fatal errors, are not issued.
- 5.3.2.7 *Output/Control*: Select operating mode of the controller output:
- Cont.:* Controller continues normally.
- Hold:* Controller continues based on the last valid value.
- Off:* Controller is switched off.

5.3.2.24

daily

The relay contact can be activated daily, at any time of a day.

5.3.2.341

Start time: to set the start time proceed as follows:

- 1 Press [Enter], to set the hours.
- 2 Set the hour with the [▲] or [▼] keys.
- 3 Press [Enter], to set the minutes.
- 4 Set the minutes with the [▲] or [▼] keys.
- 5 Press [Enter], to set the seconds.
- 6 Set the seconds with the [▲] or [▼] keys.

Range: 00:00:00–23:59:59

5.3.2.44

Run Time: see Interval

5.3.2.54

Delay: see Interval

5.3.2.6

Signal Outputs: see Interval

5.3.2.7

Output/Control: see Interval

5.3.2.24

weekly

The relay contact can be activated at one or several days, of a week. The daily starting time is valid for all days.

5.3.2.342

Calendar:

5.3.2.342.1

Start time: The programmed start time is valid for each of the programmed days. To set the start time see [5.3.2.341, p. 94](#).

Range: 00:00:00–23:59:59

5.3.2.342.2

Monday: Possible settings, on or off to

5.3.2.342.8

Sunday: Possible settings, on or off

5.3.2.44

Run Time: see Interval

5.3.2.54

Delay: see Interval

5.3.2.6

Signal Outputs: see Interval

5.3.2.7

Output/Control: see Interval

5.3.2.1

Function = Fieldbus:

The relay will be switched via the Profibus input. No further parameters are needed.

5.3.3.1 Function = End of Batch

This function is only available on relay 2. It is used to communicate with canal switching instruments from third-party suppliers. The relay closes for 1 sec. after each valid measurement. If End of Batch is selected, no further selection is possible.

5.3.3.1 Function = Channel Selection

If the 2nd sample stream option is installed, relay 2 can be used to indicate which channel is selected. No further parameters are needed.

Relay 2 inactive: Channel 1 is selected

Relay 2 active: Channel 2 is selected

5.3.4 Input: The functions of the relays and signal outputs can be defined depending on the position of the input contact, i.e. no function, closed or open.

If <Channel Selection> in Menu < Installation>/<Sensors> is set to "external", the Input is set to "Active = no" and can be used to switch the 2nd Sample Stream Option via an external device.

5.3.4.1 Active: Define when the input should be active:

The measurement is interrupted during the time the input is active.

No: Input is never active.

When closed: Input is active if the input relay is closed

When open: Input is active if the input relay is open

5.3.4.2 Signal Outputs: Select the operation mode of the signal outputs when the relay is active:

Cont.: Signal outputs continue to issue the measured value.

Hold: Signal outputs issue the last valid measured value. Measurement is interrupted. Errors, except fatal errors, are not issued.

Off: Set to 0 or 4 mA respectively. Errors, except fatal errors, are not issued.

5.3.4.3 Output/Control: (relay or signal output):

Cont.: Controller continues normally.

Hold: Controller continues on the last valid value.

Off: Controller is switched off.

- 5.3.4.4 *Fault:*
 - No:* No message is issued in pending error list and the alarm relay does not close when input is active. Message E024 is stored in the message list.
 - Yes:* Message E024 is issued and stored in the message list. The Alarm relay closes when input is active.
- 5.3.4.5 *Delay:* Time which the instrument waits, after the input is deactivated, before returning to normal operation.
Range: 0–6'000 Sec

5.4 Miscellaneous

- 5.4.1 *Language:* Set the desired language.

Language
German
English
French
Spanish

- 5.4.2 *Set defaults:* Reset the instrument to factory default values in three different ways:

Set defaults
no
Calibration
In parts
Completely

- ♦ **Calibration:** Sets calibration values back to default. All other values are kept in memory.
 - ♦ **In parts:** Communication parameters are kept in memory. All other values are set back to default values.
 - ♦ **Completely:** Sets back all values including communication parameters.
- 5.4.3 *Load Firmware:* Firmware updates should be done by instructed service personnel only.

Load Firmware
no
yes

5.4.4 Password: Select a password different from 0000 to prevent unauthorized access to the following menus:

5.4.4.1 Messages

5.4.4.2 Maintenance

5.4.4.3 Operation

5.4.4.4 Installation.

Each menu may be protected by a *different* password.

If you forgot the passwords, contact the closest SWAN representative.

5.4.5 *Sample ID:* Identify the process value with any meaning full text, such as KKS number.

5.4.6 *Line Break Detection:* If activated, error message E028 is shown in case of line break on signal outputs 1 and 2.

5.5 Interface

Select one of the following communication protocols. Depending on your selection, different parameters must be defined.

5.5.1 Protocol: Profibus

5.5.20 Device address: Range: 0–126

5.5.30 ID-Nr.: Range: Analyzer; Manufacturer; Multivariable

5.5.40 Local operation: Range: Enabled, Disabled

5.5.1 Protocol: Modbus RTU

5.5.21 Device address: Range: 0–126

5.5.31 Baud Rate: Range: 1200–115 200 Baud

5.5.41 Parity: Range: none, even, odd

5.5.1 Protocol: USB stick

Only visible if an USB interface is installed. No further settings are possible.

5.5.1 Protocol: HART

5.5.24 Device address: Range: 0–63

10. Material Safety Data Sheets

10.1. Reagents

Catalogue No.:	Part of Article No. A - 85.420. 560
Product name:	OXYCON ON-LINE SILICA Reagent 1a for AMI Silica Ammonium heptamolybdate tetrahydrate
Catalogue No.:	Part of Article No. A - 85.420. 560
Product name:	OXYCON ON-LINE SILICA Reagent 1b for AMI Silica Sodium hydroxide pellets
Catalogue No.:	Part of Article No. A - 85.420. 560
Product name:	OXYCON ON-LINE SILICA Reagent 2 for AMI Silica Sulfuric acid 25 %
Catalogue No.:	Part of Article No. A - 85.420. 560
Product name:	OXYCON ON-LINE SILICA Reagent 3 for AMI Silica Oxalic acid dihydrate
Catalogue No.:	Part of Article No. A - 85.420. 560
Product name:	OXYCON ON-LINE SILICA Reagent 4a for AMI Silica Sulfuric acid 25 %
Catalogue No.:	Part of Article No. A - 85.420. 560
Product name:	OXYCON ON-LINE SILICA Reagent 4b for AMI Silica Ammonium iron(II) sulfate hexahydrate
Catalogue No.:	A85.142.400
Product name:	Silica Standard 100ppm 100ml

**Download
MSDS**

The current Material Safety Data Sheets (MSDS) for the above listed Reagents are available for downloading at www.swan.ch.

11. Default Values

Operation:

Sensors:	Filter Time Const.:.....	10 s
	Hold after Cal.:.....	300 s
Alarm Relay	same as in Installation
Relay 1 and 2	same as in Installation
Input	same as in Installation
Logger	Logger Interval:.....	Event Driven
	Clear Logger:.....	no

Installation:

Sensor	Ref. Verification:.....	0.235
	Standard:.....	100 ppb
	Blank.....	0.0 ppb
	Meas. interval.....	10 min
	Channels.....	1
	Channel Selection.....	internal
Signal Output 1	Parameter:.....	Si 1
	Current loop:.....	4 – 20 mA
	Function:.....	linear
	Scaling: Range low:.....	0.0 ppb
	Scaling: Range high:.....	1.00 ppm
Signal Output 2	Parameter:.....	Temperature
	Current loop:.....	4 – 20 mA
	Function:.....	linear
	Scaling: Range low:.....	0.0 °C
	Scaling: Range high:.....	50.0 °C
Alarm Relay	Alarm Si 1:	
	Alarm high:.....	5.00 ppm
	Alarm low:.....	0.0 ppb
	Hysteresis:.....	10 ppb
	Delay:.....	5 s
	Sample Temp.: Alarm High:.....	55 °C
	Sample Temp.: Alarm Low:.....	5 °C
	Sample Flow: Flow Alarm:.....	yes
	Sample Flow: Alarm High:.....	500 B/s
	Sample Flow: Alarm Low:.....	5 B/s
	Case temp. high:.....	65 °C
	Case temp. low:.....	0 °C

Relay1 and 2	Function: limit upper Parameter: Si 1 Setpoint: 1.0 ppm Hysteresis: 10 ppb Delay: 30 s If Function = Control upw. or dnw: Parameter: Si 1 Settings: Actuator: Frequency Settings: Pulse Frequency: 120/min Settings: Control Parameters: Setpoint: 1.00 ppm Settings: Control Parameters: P-band: 10 ppb Settings: Control Parameters: Reset time: 0 s Settings: Control Parameters: Derivative Time: 0 s Settings: Control Parameters: Control Timeout: 0 min Settings: Actuator: Time proportional Cycle time: 60 s Response time: 10 s Settings: Actuator Motor valve Run time: 60 s Neutral zone: 5% If Function = Timer: Mode: Interval Interval: 1 min Mode: daily Start time: 00.00.00 Mode: weekly Calendar; Start time: 00.00.00 Calendar; Monday to Sunday: Off Run time: 10 s Delay: 5 s Signal output: cont Output/Control: cont
Input	Active when closed Signal Outputs hold Output/Control off Fault no Delay 10 s
Miscellaneous	Language: English Set default: no Load firmware: no Password: for all modes 0000 Sample ID: - - - - - Line break detection no

12. Index

A			
Alarm Relay	12, 32		
Ammonium Ferrous Sulfate			
Reagent 4	52		
Ammoniummolybdate			
Reagent 1	52		
Application Range	11		
C			
Cable thicknesses	27		
Calendar	94		
Changing values	47		
Constant Head	55		
D			
Default Values	99		
E			
Electrical wiring	19		
Error List	64		
F			
Fill System	81		
Filter Time Constant	82		
Fluidics	12		
H			
Hold after Cal	82		
I			
I/O State	81		
Input	12, 32, 95		
Instrument Setup	19		
Interface			
HART	37		
Interface Modbus	36		
Interface Profibus DP	36		
Interface RS485	36–37		
Interface USB	37		
L			
Log Interval	83		
Logger	83		
M			
Manual Filling	81		
Measurement cycle	14		
Measurement interval	51		
Messumformer	18		
Mode External	84		
Mode Fieldbus	84		
Mode Internal	84		
Mounting requirements	20		
O			
On-site requirements	17, 19		
Oxalic Acid			
Reagent 3	52		
P			
Power Supply	16, 31		
Power-up	19		
Program Access	43		
Programming	42		
R			
Reagent 1			
Ammoniummolybdate	52		
Reagent 2			
Sulfuric Acid	52		
Reagent 3			
Oxalic Acid	52		
Reagent 4			



Ammonium Ferrous Sulfate . . .	52	Silica Measurement	11
Reagent consumption	51	Simulation	82
Reagents	19	Sulfuric Acid	
Relay	11	Reagent 2	52
Run-in period	19		
S		T	
Safety Features	12	Terminals	29–30, 32–33, 35–36
Sample Flow		Transmitter	18
Establish	39		
Signal Outputs	11, 35	W	
Signal Sequencer	88	Wire	27

Swan Products - Analytical Instruments for:



Swan is represented worldwide by subsidiary companies and distributors and cooperates with independent representatives all over the world. For contact information, please scan the QR code.

Swan Analytical Instruments · CH-8340 Hinwil
www.swan.ch · swan@swan.ch

SWISS  MADE

