

Complete monitoring system for the automatic, continuous measurement of specific conductivity and conductivity after cation exchange with continuous EDI resin regeneration.
 Calculation of sample pH and alkalizing reagent concentration based on differential conductivity measurement.

Application examples

- Uninterrupted monitoring of steam and condensate quality in power and industrial plants:
 no need for regular resin exchange and the associated rinsing times and no risk of resin exhaustion.

Measuring range

- Conductivity: 0.055 to 1000 $\mu\text{S}/\text{cm}$.
 Temperature compensation to 25 °C with various models:
 non-linear for high purity water, neutral salts, strong acids, strong bases, ammonia, ethanolamine, morpholine or linear with coefficient.
- pH: 7.5 to 11.5 (calculated; directive VGB-S-010-T-00).
- Concentration: 0.01 to 10 ppm ammonia (calculated).

Instrument features

- Continuous operation with automatic regeneration of the cation exchange resin by electrodeionization (EDI).
- EDI module with exchangeable sample chamber module.
- Flow cell CATCON+ SL CACE and conductivity sensors UP-CON1000 SL with patented slot-lock design for quick sensor release.
- Instrument protection with optional sample filtration.

On-board quality assurance

- Integrated sample flowmeter for measurement validation.
- Tracking of operational parameters of the EDI module to monitor the service life of the sample chamber.

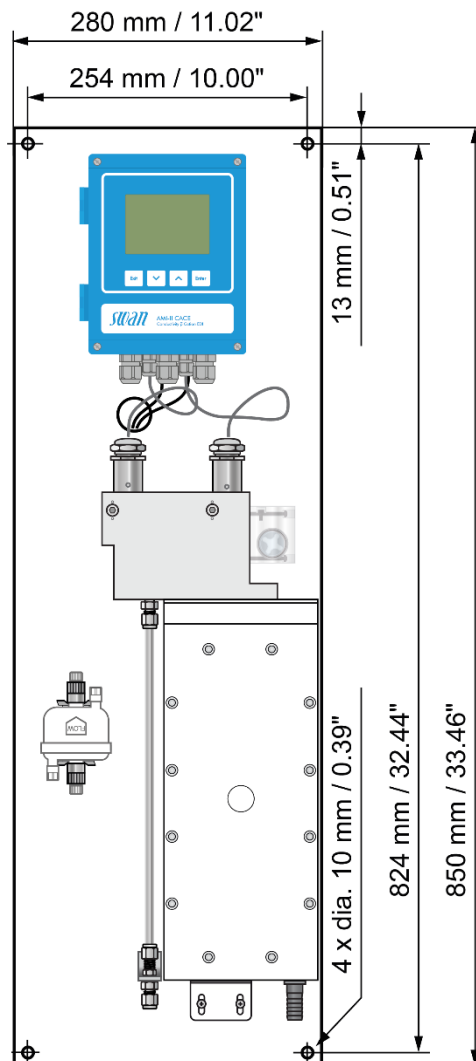

Order numbers:	AMI-II CACE	A-23.562._00
Power supply	100 – 240 VAC, 50/60 Hz 10 – 36 VDC.....	1 2
Option 1	RS485 interface with Modbus RTU or Profibus protocol HART interface Two additional 0/4 – 20 mA signal outputs	A-81.470.0x0 A-81.470.030 A-81.470.040
Option 2	Inlet filter (1 μm)	A-82.811.040
Accessories	Backpressure regulator, 1 channel with manometer Verification adapter	A-82.581.001 A-83.910.130



Conductivity Measurement

Conductivity sensor type

2-electrode conductivity sensor UP-Con1000-SL with integrated temperature probe.

Measuring range

0.055 to 0.999 $\mu\text{S}/\text{cm}$
 1.00 to 9.99 $\mu\text{S}/\text{cm}$
 10.0 to 99.9 $\mu\text{S}/\text{cm}$
 100 to 999 $\mu\text{S}/\text{cm}$
 Automatic range switching.

Resolution

0.001 $\mu\text{S}/\text{cm}$
 0.01 $\mu\text{S}/\text{cm}$
 0.1 $\mu\text{S}/\text{cm}$
 1 $\mu\text{S}/\text{cm}$

Accuracy (at 25 °C) $\pm 1\%$ of measured value or ± 1 digit (whichever is greater).

Response time (t_{90} , specific cond.) < 5 s

Temperature compensations

Non-linear function (NLF) for high purity water, neutral salts, strong acids, strong bases, ammonia, ethanolamine, morpholine, linear coefficient 0.00 – 10.00 $\%/^{\circ}\text{C}$, absolute (none). Influence of temperature see PPChem 2012 14(7) [Wagner].

pH and alkalinizing reagent calculation

Ranges (25 °C)

pH: 7.5 to 11.5
 e.g. ammonia: 0.01 to 10 ppm

Auxiliary sensors

- Temperature measurement with Pt1000 type sensors (DIN class A).
 Measuring range: -30 to $+250$ °C
 Accuracy (0-50 °C) ± 0.25 °C
 Resolution: 0.1 °C
- Sample flow measurement with digital SWAN sample flow sensor.

Transmitter Specifications and Functionality

Electronics case: Cast aluminum
 Protection degree: IP66 / NEMA 4X
 Display: backlit LCD, 74 x 53 mm
 Electrical connectors: screw clamps
 Ambient temperature: -10 to $+50$ °C
 Humidity: 10 - 90% rel., non-condensing

Power supply

AC version: 100 – 240 VAC (± 10 %),
 50/60 Hz (± 5 %)
 DC version: 10 – 36 VDC
 Power consumption: max. 35 VA

Operation

User menus in English, German, French, Spanish and Chinese.
 Separate, menu-specific password protection.

Safety features

No data loss after power failure, all data is saved in non-volatile memory.
 Overvoltage protection of inputs and outputs.
 Galvanic separation of measuring inputs from signal outputs.

Electrical Connection Scheme

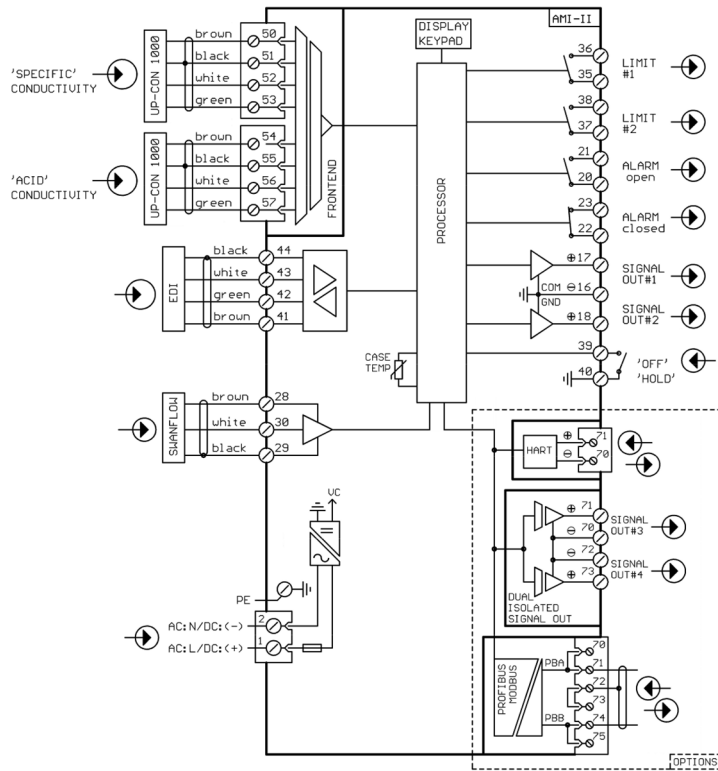

Alarm relay

Two potential-free contacts for summary alarm indication for programmable alarm values and instrument faults (one normally open and one normally closed contact).
 Maximum load: 100 mA / 50 V

Input

One input for potential-free contact.
 Programmable hold or remote off function.

Relay outputs

Two potential-free contacts programmable as limit switches for measured values, controllers or timers with automatic hold function.
 Rated load: 100 mA / 50 V

Signal outputs

Two or four (with optional communication interface) programmable signal outputs for measured values (freely scalable, linear or bilinear) or as controller outputs.
 Current loop: 0/4 – 20 mA
 Maximum burden: 510 Ω
 Type: current source

SD card interface

Possibility to record measured values and diagnostic data to an SD card.
 SD card included.

Communication interface options

- Two additional signal outputs, galvanically separated
- RS485 interface with Modbus RTU or Profibus DP protocol, galvanically separated
- HART interface

Monitor Data

Sample conditions

Flow rate: 3 to 4 L/h
 Temperature: up to 50 °C
 Inlet pressure (25 °C): 0.5 bar
 Outlet pressure: pressure free
 No sand, no oil

EDI capacity:

$sc_{max} = 40$ $\mu\text{S}/\text{cm}$ as NH_4OH
 $sc_{max} = 350$ $\mu\text{S}/\text{cm}$ as NaOH

The use of SWAN Back Pressure Regulator is highly recommended. Particle filtration recommended in case of high iron concentration. Use of film forming products may reduce lifetime of EDI module.

Sample connections

Sample inlet: Swagelok 1/4" tube adapter
 Sample outlet: G 3/8" adapter for flexible tube \varnothing 20 x 15 mm

Panel

Dimensions: 280 x 850 x 180 mm
 Material: stainless steel
 Total weight: 14 kg

