

Portable inspection equipment for quality assurance of conductivity monitors.

## AMI INSPECTOR Conductivity

Complete portable system mounted on small, aluminum panel:

- **Transmitter AMI INSPECTOR Conductivity** in a rugged aluminum enclosure (IP 66).
- **Swansensor UP-Con1000-SL** two-electrode conductivity sensor with slot-lock design and integrated Pt1000 temperature probe.
- **Flow cell QV-Flow UP-CON-SL** made of stainless steel with flow adjustment valve and digital sample flow meter. Quick sensor release with patented slot-lock design.
- Rechargeable battery for stand-alone operation.
- Carrying case
- USB Stick for data logging.
- Factory tested, ready for installation and operation.



### Specifications:

- Conductivity measurement range: 0.055  $\mu$ S/cm to 30 mS/cm
- Big LC display for the reading of measuring value, sample temperature, sample flow, temperature compensation type, operating status and battery charge condition.
- Easy user menus in English, German, French and Spanish. Simple programming of all parameters by keypad.
- Wide range of selectable temperature compensations for different sample conditions.
- Electronic record of major process events and calibration data.
- Data logger for 1'500 data records stored at a selectable interval.
- One current output (0/4 - 20 mA) for measured signal.

### Optional:

- Instrument certificate

<b>Order Nr.</b>	<b>AMI INSPECTOR Conductivity</b>	<b>A-75.310.000</b>
Option:	[ ] Instrument certificate	A-97.017.310

## Conductivity Measurement

**Swansensor UP-Con1000-SL** with integrated Pt1000 temperature probe ( $k = 0.0415 \text{ cm}^{-1}$ ).

Measuring range	Resolution
0.055 to 0.999 $\mu\text{S/cm}$	0.001 $\mu\text{S/cm}$
1.00 to 9.99 $\mu\text{S/cm}$	0.01 $\mu\text{S/cm}$
10.0 to 99.9 $\mu\text{S/cm}$	0.1 $\mu\text{S/cm}$
100 to 999 $\mu\text{S/cm}$	1 $\mu\text{S/cm}$
1.00 to 2.99 $\text{mS/cm}$	0.01 $\text{mS/cm}$
3.0 to 9.9 $\text{mS/cm}$	0.1 $\text{mS/cm}$
10 to 30 $\text{mS/cm}$	1 $\text{mS/cm}$

Automatic range switching.

### Accuracy

$\pm 1\%$  of measured value or  $\pm 1$  digit (whichever is greater).

### Temperature compensations

- Non linear function (NLF) for high purity water
- Neutral salts
- Strong acids
- Strong bases
- Ammonia, Ethanolamine
- Morpholine
- Linear coefficient in  $\%/\text{C}$
- Absolute (none)

### Temperature measurement

Measuring range:  $-30$  to  $+130 \text{ }^\circ\text{C}$   
Resolution:  $0.1 \text{ }^\circ\text{C}$

### Sample flow measurement

with digital SWAN sample flow sensor.

## Transmitter Specifications and Functionality

Electronics case: Cast aluminum  
Protection degree: IP 66 / NEMA 4X  
Display: LCD, 75 x 45 mm  
Electrical connectors: screw clamps  
Dimensions: 180 x 140 x 70 mm  
Weight: 1.5 kg  
Ambient temperature:  $-10$  to  $+50 \text{ }^\circ\text{C}$   
Humidity: 10 - 90% rel., non condensing

### Power supply - Battery

Use original power adapter only.  
Voltage: 85 - 265 VAC, 50/60 Hz  
Power consumption: max. 20 VA  
Charging time:  $\sim 6$  h  
Battery type: Li-Ion  
During charging protect from heat impact and keep splash-proof (not IP66).

### Operating time

Stand-alone (Battery):  $> 24$  h  
Connected adapter: continuous  
Controlled shut-down when battery is empty, remaining time is displayed.

### Operation

Easy operation based on separate menus for "Messages", "Diagnostics", "Maintenance", "Operation" and "Installation". User menus in English, German, French and Spanish.

Separate menu specific password protection.  
Display of process value, sample flow, alarm status, time and battery charge condition.  
Storage of event log, alarm log and calibration history.  
Storage of the last 1'500 data records in logger with selectable time interval.

### Safety features

No data loss after power failure, all data is saved in non-volatile memory.  
Overvoltage protection of in- and outputs.  
Galvanic separation of measuring inputs and signal outputs.

### Transmitter temperature monitoring

with programmable high/low alarm limits.

### 1 Alarm relay

One potential free contact for summary alarm indication for programmable alarm values and instrument errors.  
Maximum load: 1A / 250 VAC

### 1 Input

One input for potential-free contact.  
Programmable hold or remote off function.

### 2 Relay outputs

Two potential-free contacts programmable as limit switches for measuring values, controllers or timer for system cleaning with automatic hold function.  
Rated load: 100 mA / 50 V

## Electrical Connection Scheme

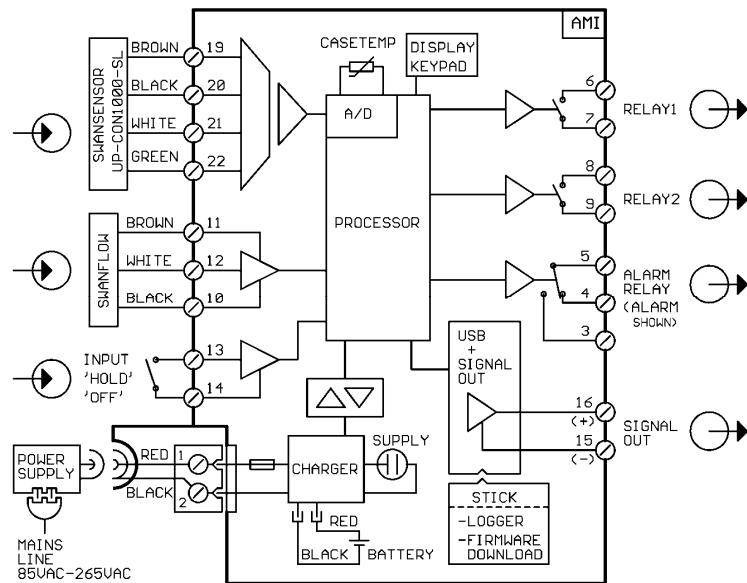

### 1 Signal output

One programmable signal output for measured value (freely scaleable, linear or bilinear) or as continuous control outputs (control parameters programmable).  
Current loop: 0/4 - 20 mA  
Maximum burden: 510  $\Omega$

### Control functions

Relays or current outputs programmable for 1 or 2 pulse dosing pumps, solenoid valves or for one motor valve.  
Programmable P, PI, PID or PD control parameters.

### 1 Communication interface

USB Stick for logger data.

## Monitor Data

### Sample conditions

Flow rate: 5 to 20 L/h  
Temperature: up to  $50 \text{ }^\circ\text{C}$   
Inlet pressure ( $25 \text{ }^\circ\text{C}$ ): up to 2 bar  
Outlet pressure: pressure free  
No sand, no oil

### Flow cell and connections

Flow cell made of stainless steel with built-in flow adjustment valve and digital sample flow meter. Quick sensor re-lease with patented slot-lock design.

Inlet:  $\frac{1}{4}$ " Swagelok tube adapter  
Outlet: flexible tube adapter 6 x 8 mm

### Panel

Dimensions: 275 x 320 x 240 mm  
Material: anodized aluminum  
Total weight: 4.5 kg