

Complete monitoring system for the automatic, continuous measurement of silica in water steam cycles.

### Monitor AMI Silica

- Measuring range: 1 to 5'000 ppb
- Based on colorimetric measurement principle.
- Complete system including measurement and control electronics, photometer with integrated reaction chamber, flow indicator, reagent dosing system and reagent containers.
- Measurement values are available as analog output signals.
- Alarm display and activation of alarm relay when user defined, critical limits are reached.
- Continuous, automatic monitoring of main instrument functions (sample flow, reagent supply).
- Large back-lit LCD display showing all measured values and status information simultaneously.
- Easy user menus in English, German, French and Spanish. Simple programming of all parameters by keypad.
- Data logger for 1'500 data records stored at a selectable interval.
- Factory tested, ready for installation and operation.

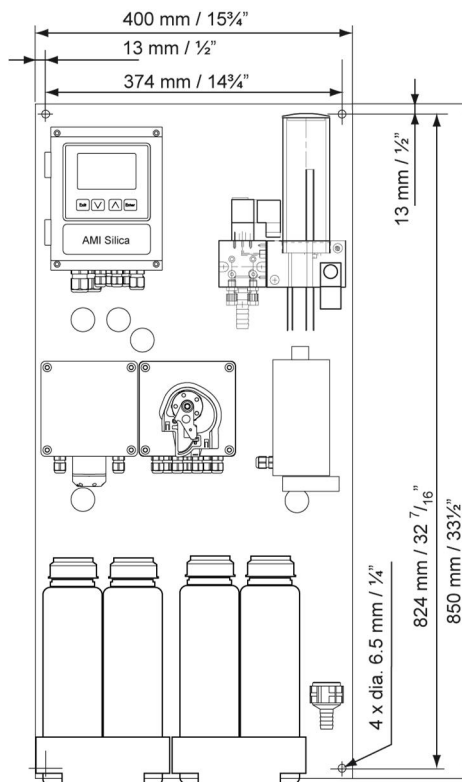

Monitor AMI Silica

### Instrument Options

- Communication interface (Profibus, Modbus, 3<sup>rd</sup> Signal Output, USB, HART).
- 2<sup>nd</sup> sample stream.

### Accessories

- AMI Sample Sequencer, switching up to 6 sample streams.

Order Nr.	Monitor AMI Silica AC	A-25.431.000
	Monitor AMI Silica DC	A-25.432.000
Option 1:	[ ] 3 <sup>rd</sup> current signal output (0/4 – 20mA)	A-81.420.050
	[ ] Profibus DP & Modbus RTU interface (RS-485)	A-81.420.020
	[ ] USB interface	A-81.420.042
	[ ] HART interface	A-81.420.060
Option 2:	[ ] 2 <sup>nd</sup> sample stream	A-83.590.043

## Analytical System

Colorimetric, Molybdosilicat method.

### Silica measurement

Measuring range: 1 to 5'000 ppb  
Reproducibility:  $\pm 1$  ppb or  $\pm 5\%$ ,  
whichever is greater  
Cycle time: 10'  
Measurement interval: 10', 15', 20' or 30'

### Flow cell

Made of acrylic glass with water inlet and flow adjustment valve.

## Transmitter Specifications and Functionality

Electronics case: Aluminum  
Protection degree: IP 66 / NEMA 4X  
Display: backlit LCD, 75 mm x 45 mm  
Electrical connectors: screw clamps  
Ambient temperature: -10 to +50 °C  
Limit range of operation: -25 to +65 °C  
Storage and transport: -30 to +85 °C  
Humidity: 10 to 90 % relative,  
non condensing

### Power supply

Voltage:  
AC version: 100 - 240 VAC ( $\pm 10\%$ )  
50/60 Hz ( $\pm 5\%$ )  
DC version: 10-36 VDC  
Power consumption: max. 35 VA

### Operation

Easy operation based on separate menus for "Messages", "Diagnostics", "Maintenance", "Operation" and "Installation".  
Separate menu specific password protection possible.  
Display of process value, sample flow, alarm status and time during operation.  
Storage of event log, alarm log and calibration history.  
Storage of the last 1'500 data records in logger with selectable time interval.

### Safety features

No data loss after power failure, all data is saved in non-volatile memory. Over voltage protection of in- and outputs. Galvanic separation of measuring inputs and signal outputs.

### Transmitter temperature monitoring

With programmable high/low alarm limits.

### Real-time clock with calendar

For action time stamp and pre-programmed actions.

### Monitoring of reagent consumption

Warning if low level is reached and alarm for lack of reagents.

### 1 Alarm relay

One potential free contact for summary alarm indication for programmable alarm values and instrument faults.  
Maximum load: 1A / 250 VAC

## Electrical Connection Scheme

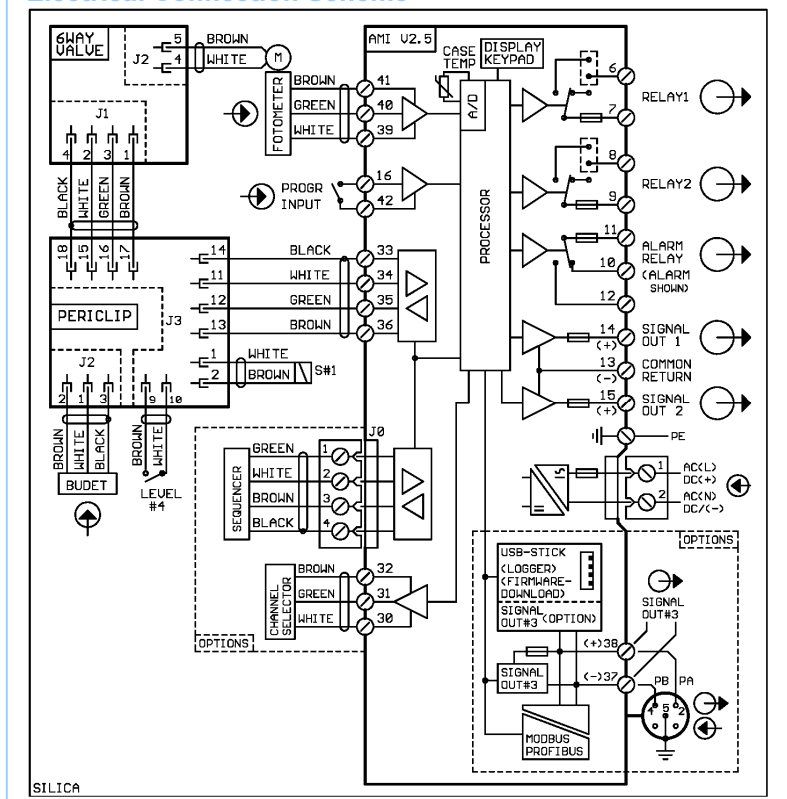

### 1 Input

One input for potential-free contact. Programmable hold or remote off function

### 2 Relay outputs

Two potential-free contacts programmable as limit switches for measuring values, controllers or timer with automatic hold function.  
Max. load: 1A / 250 VAC

### 2 Signal outputs (3<sup>rd</sup> as option)

Two programmable signal outputs for measured values (freely scalable, linear or bilinear) or as continuous control output (control parameters programmable) as current source. 3<sup>rd</sup> signal output selectable as current source or current sink.  
Current loop: 0/4 - 20 mA  
Maximum burden: 510  $\Omega$

### Control function

Relays or current outputs programmable for 1 or 2 pulse dosing pumps, solenoid valves or for one motor valve. Programmable P, PI, PID or PD control parameters.

### 1 Communication interface (option)

- RS485 interface (galvanically separated) with Fieldbus protocol Modbus RTU or Profibus DP
- 3<sup>rd</sup> Signal output
- USB interface
- HART interface

## Sample and Monitor Data

### Sample conditions

Flow rate: min. approx. 10 l/h  
Temperature: up to 50 °C  
Inlet pressure: 0.15 to 2 bar  
Outlet pressure: pressure free, atmospheric drain  
Phosphate (as PO<sub>4</sub>): < 10 ppm

### Sample connections

Inlet: Serto PVDF 6 mm (1/8"),  
for tubing 4x6 mm  
Drain:  $\varnothing$  16 mm, tubing 15x20 mm

### Panel

Dimensions: 400 x 850 x 160 mm  
Material: stainless steel  
Weight: 16.0 kg